

Advanced Electrical Materials MSPro I 4 Profiler



DISCLAIMER

Please note that all product, product specifications and data detailed in this brochure are subject to change without notice to improve reliability, function, design or otherwise. Morgan AM&T B.V. and its affiliates does not assume any responsibility for the correctness of this information nor for damages consequent to its use. Statements regarding the suitability of products for certain types of applications are based on knowledge of typical requirements that are often placed on Morgan products in generic applications

Safety

NB when working on rotating electrical equipment it is essential that basic safety guidelines are observed, e.g. ensure equipment is fully isolated before any work commences.

Check with the site Health & Safety representative before conducting any work to ensure local safety procedures are complied with.



CONTENTS PAGE

Introduction	1
Recommendations	4
First time Use	5
Minimum PC requirements:	5
Registration of software on 1st use	6
Software update procedure	11
Using the MSPro14 Measuring Box	12
Welcome Screen	13
Home Screen	14
Settings.....	15
Date & Time	15
Units & Language	16
Alarms.....	16
Display	17
Power Management.....	17
Sensor Settings.....	18
Start Measurement.....	19
Commutator	19
Setting the Sensor	21
Completing one Recording.....	24
Slip-ring.....	31
Setting the Sensor	32
Completing one Recording.....	33
View Data	38
Standby Screen	40
PC Analysis Software	43
DASPro14	43
General.....	43
User Interface.....	43
Using DASPro14 for the first time	46
Using DASPro14	46

Adding Datasets.....	46
Printing	48
Reading and Comparing Values	49
Adjusting Profiles	49
Zooming behaviour	50
Alarms	50
Downloading .Mas files	50
Appendix A: Specifications	51
Appendix B: Warranty & Repairs	52
Warranty.....	52
Repairs & Calibration.....	52

INTRODUCTION

The primary object of maintaining or reconditioning a commutator or slip ring (Collector) is to remove those irregularities which lead to impaired brush efficiency and reduced brush and collector life. Collectors should, in an ideal world, be smooth and true. A collector that is in bad condition should be either re-ground or turned.

In general, collectors with a Total Indicated Runout (TIR) of 76µm (3 mil) or greater and on a commutator with a Maximum Bar-to-Bar Height (MBTB) of 7.6 µm (0.3 mil) or greater needs to be re-ground or turned:

Situation	Runout (TIR)	Bar to Bar Variance	Undercut Depth
NEW	Less than .0015" (38µm)	Less than .0002" (5µm)	.050 (1.3mm) or more
IN SERVICE	Less than .003" (76µm)	Less than .0003" (7.6µm)	.020 (0.5mm) or more
NEEDS REPAIR	More than .003" (76µm)	More than .0003" (7.6µm)	.010 (0.25mm) or less

Regular use of a profiling device such as the MSPro14 will help to confirm whether there is a problem with the collector and this should be done at least every six months and if possible every 2 months. Trending this information will help better plan maintenance schedules.

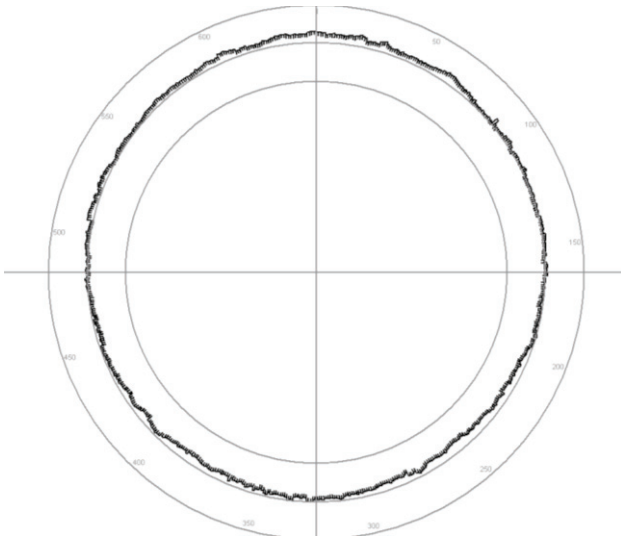

An acceptable commutator Profile

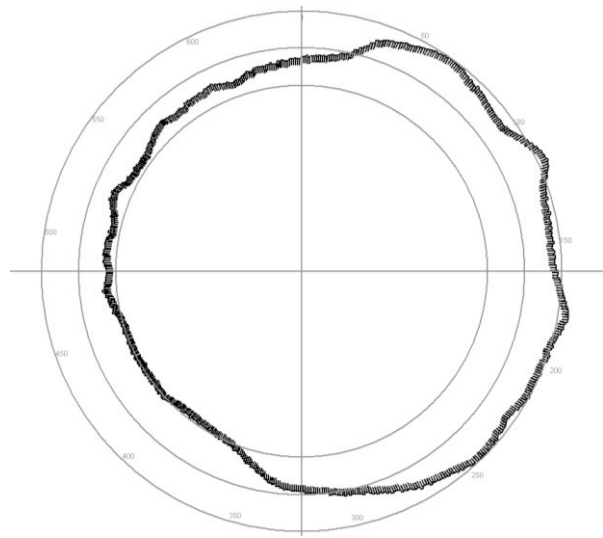

An unacceptable commutator profile

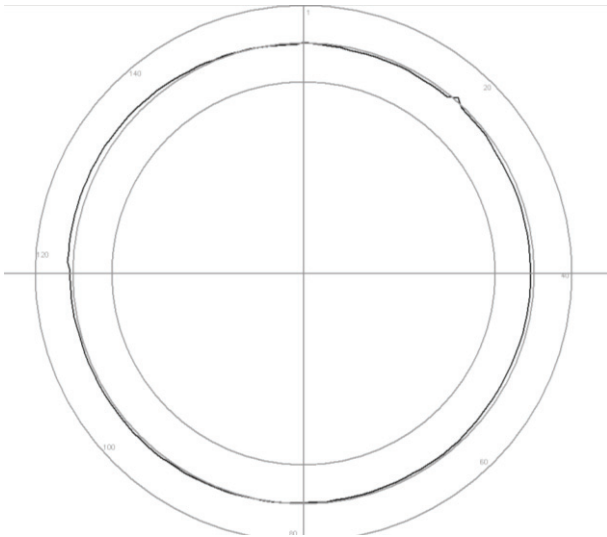

An acceptable slip ring profile

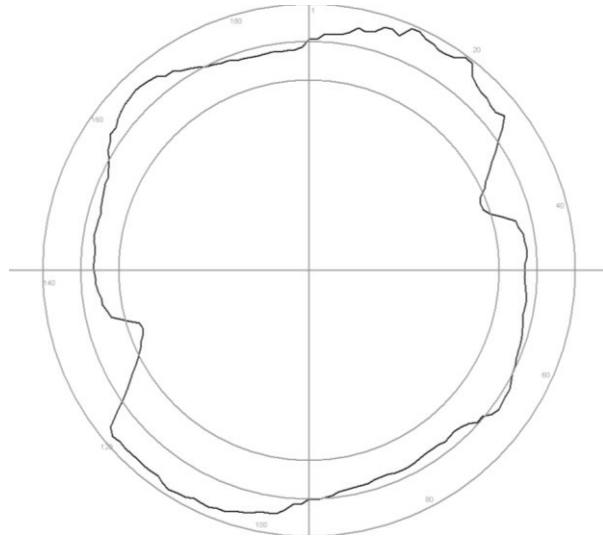

An unacceptable slip ring profile

Therefore congratulations on purchasing the MSPro14 – the new and improved Surface Profiler from Morgan Advanced Materials. The MSPro14 is used for:

- Collector surface profiling and measures TIR, MBTB as well as collector diameter
- The TIR for collectors is the difference between the minimum height and the maximum height. The TIR is also referred to as the 'runout' or 'out of roundness'.
- The MBTB Height for commutators is the maximum height difference between two adjacent bars. The MSPro14 can also determine when there are high micas present on Commutators. High Micras occur when there appears to be no gap between two consecutive bars. High Micras will be indicated as a bar number in the edit recordings dialog window.
- The MSPro14 takes recordings in what the industry knows as 'shape' mode. Shape mode takes readings as the sensor moves over the collector surface and using these values it is able to generate a shape of the collector. Shape mode records a large number of samples, thus enabling a profile to be recorded allowing wear patterns and irregularities to be inspected.

- Peak height mode can be selected (in the DASPro14 software) and is where one value per bar is displayed – this being the peak height of multiple samples taken across the entire bar.
- Collected data can be transferred to a PC where it can be analysed in detail using the DASPro14 Windows based software supplied in the kit.

The MSPro14 also offers:

- A solid easy to mount sensor that can be fitted to a vast range of holder sizes, and is rugged enough to cope with extreme environments including vibration
- Easy to use responsive industrial colour touch screen
- Optimised sensor head that is not negatively affected by Helically Grooved Slip Rings
- Zero setting light indicators for easy set up
- Previous Morgan supplied profiler measurements (.mas files) can be stored and combined
- Extra extensive memory for storing information and editable on the data acquisition box
- Comes in a robust carrying case including all attachments

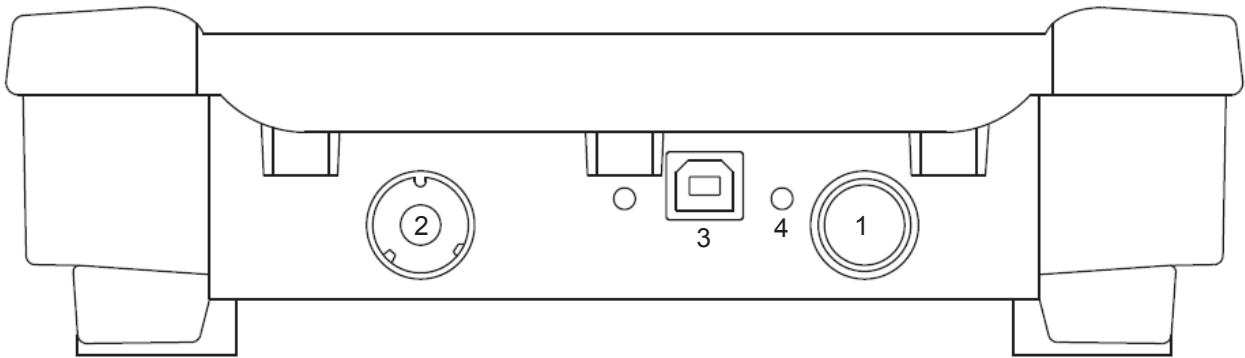

On/off button (1)

Sensor lead port (2)

USB port (3)

LED display showing 3 different colours: (4)

- **Green** = Device is on
- **Orange** = Device is on and charging
- **Red** = Device is off and charging

Standard Kit Items:

Included in the MSPro14 package which is supplied in a robust lightweight case including:

- Data Acquisition Unit (the measuring box)
- USB stick containing this manual and latest PC software (DASPro14 - Data Analysis Software)
- Sensor
- Protective Sensor sleeve and sensor spacer set
- USB cable
- AC power adaptor
- External Battery
- G (or C)-Clamp
- Flashlight & pen

RECOMMENDATIONS

Read this manual prior to installing the software and using the device for the first time. All instructions included in the manual must be followed.

Remove any loose dirt/debris from the collector surface prior to taking a profile and always ensure that the sensor head is clean before taking any readings as this could affect the results of the profile severely. Use a clean, lint free cloth for this, for example, spectacle lens cleaning cloths

The sensor head is a highly accurate piece of equipment, and although constructed to withstand normal handling, it should be treated with care at all times. The sensor should always be stored in its supplied sleeve when not in use.

When recording a profile, the results will be more consistent when the sensor is mounted as radially as possible (ideally $\pm 1^\circ$) and when rotated in the direction as indicated in the figure below.

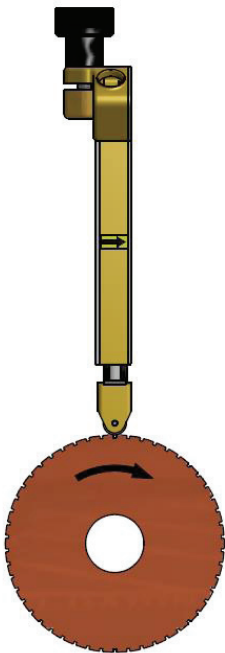

Under no circumstances should the sensor be clamped directly – it should always be fitted in a holder or sleeve and the sleeve held in place with a clamp.

It is recommended that the sensor is calibrated every 12 months – this can either be done by sending your MSPro14 to your local Morgan Sales office or directly to Morgan Advanced Materials Netherlands.

FIRST TIME USE

Minimum PC requirements:

- Operating system: Windows XP or higher
- Minimal 100MB of free disk space
- Minimum of 1GB RAM memory
- One free USB 2.0 port

Once connected to a PC using the USB-cable, the Measuring Box reports itself as new USB-device. The Measuring Box may be accessed using a Windows File Explorer standard program. This enables the user to:

- Access files stored in the Flash memory of the Measuring Box (note that each measurement results in one file)
- update the Measuring Box software

Registration of software on 1st use

Insert the supplied USB Memory stick into the PC and open the file; double-click on the software link which looks like:

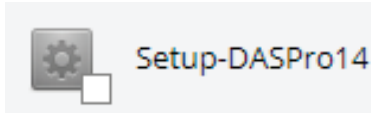

Follow the on-screen instructions; if there are any warnings displayed regarding the software installation which could depend on your PC configuration, then press “Yes”, however, if in doubt always contact your IT administrator.

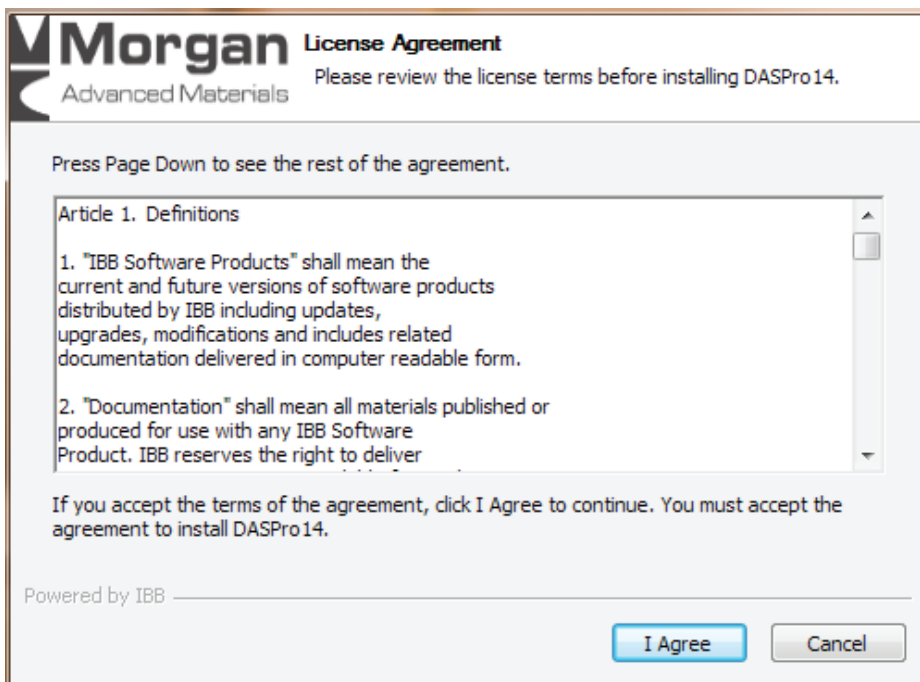

Press “I agree” to continue

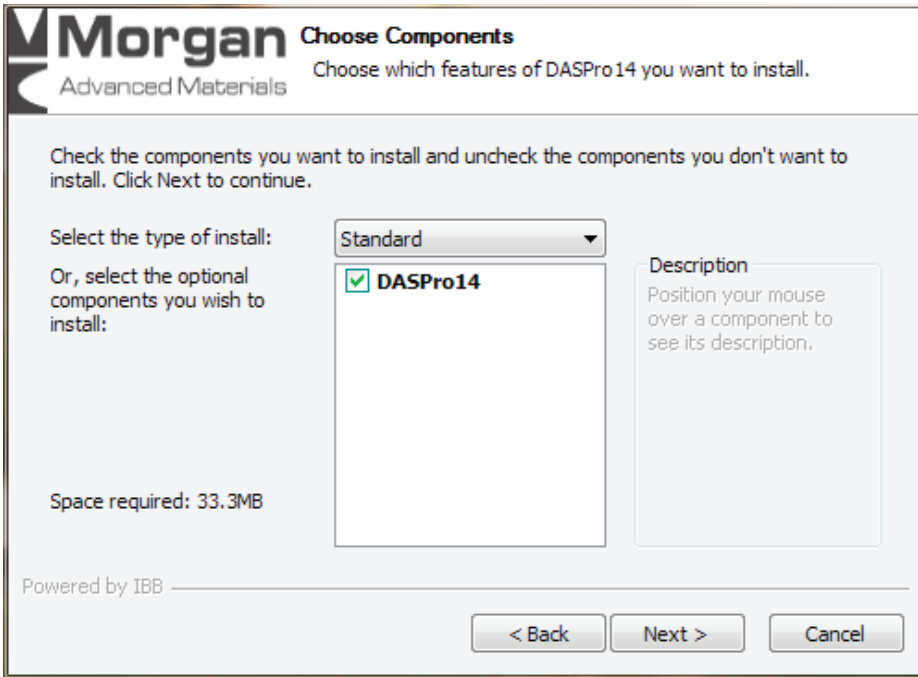

Click Next

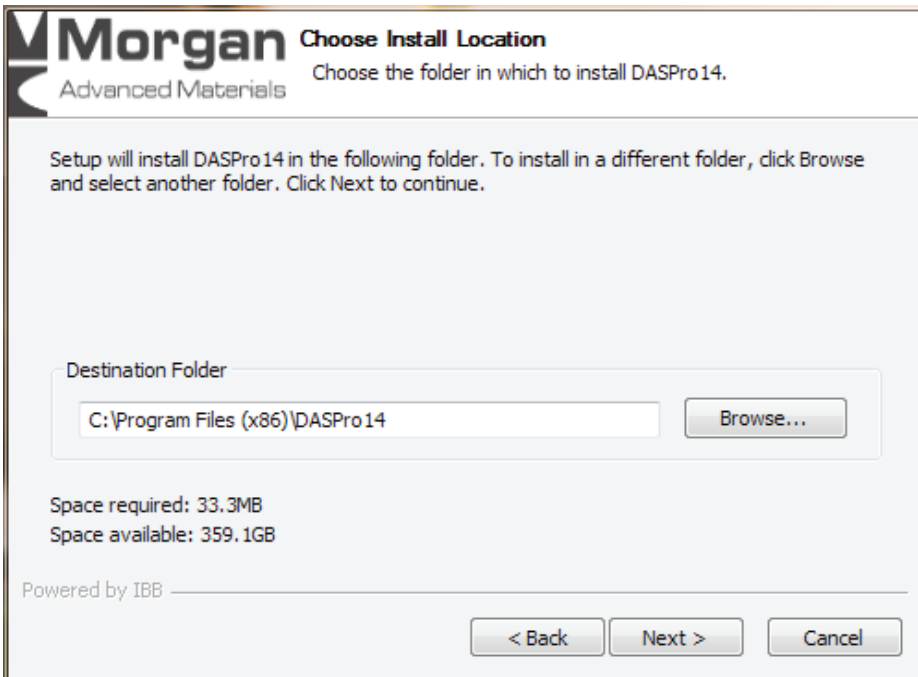

The default file location is selected; however, change if you require and click "Next" to continue

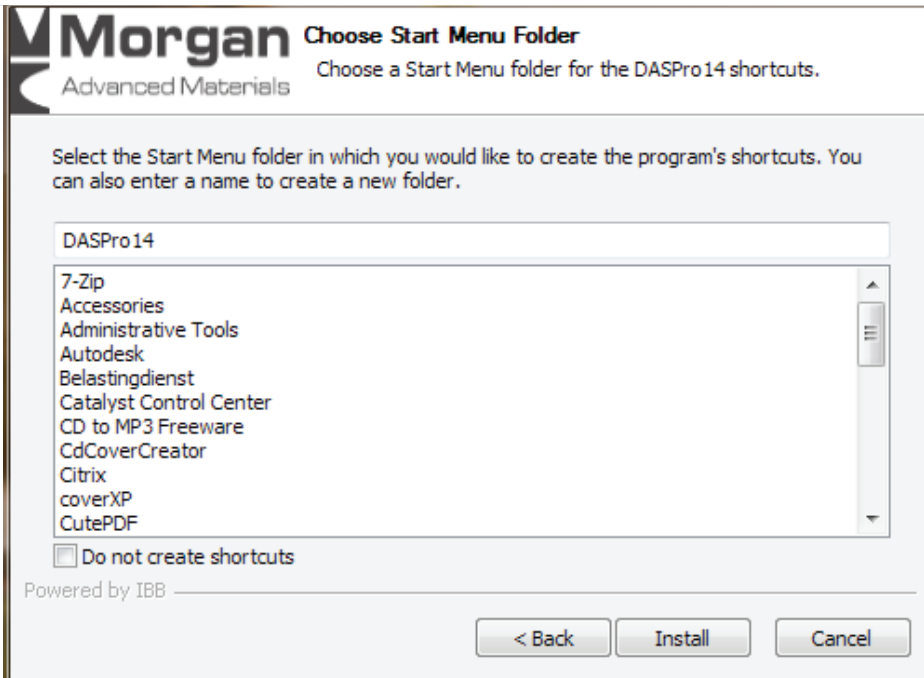

Once details are correct, press "Install"

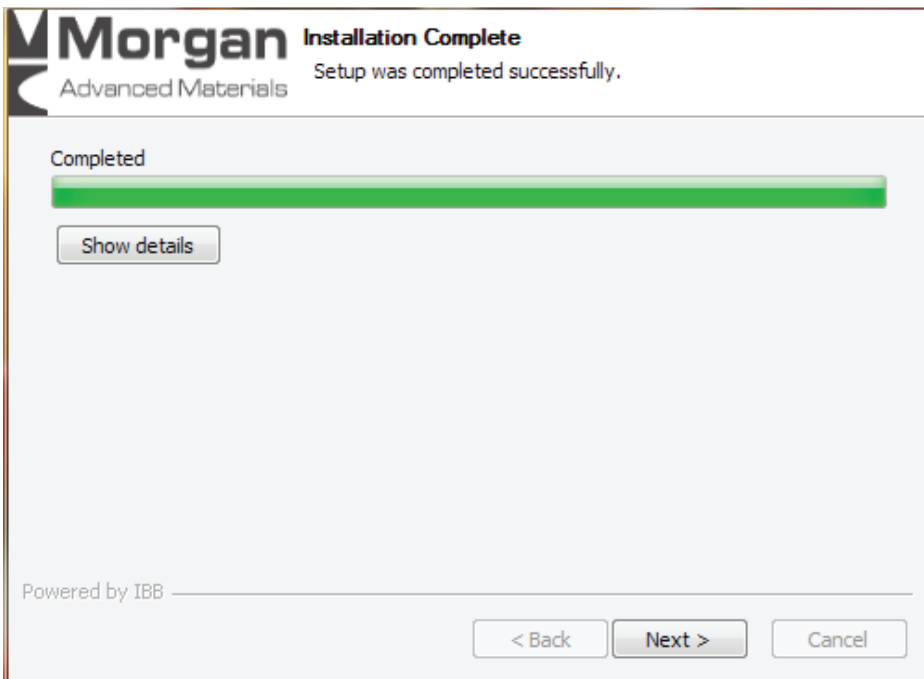

Once installation is complete, press "Next"

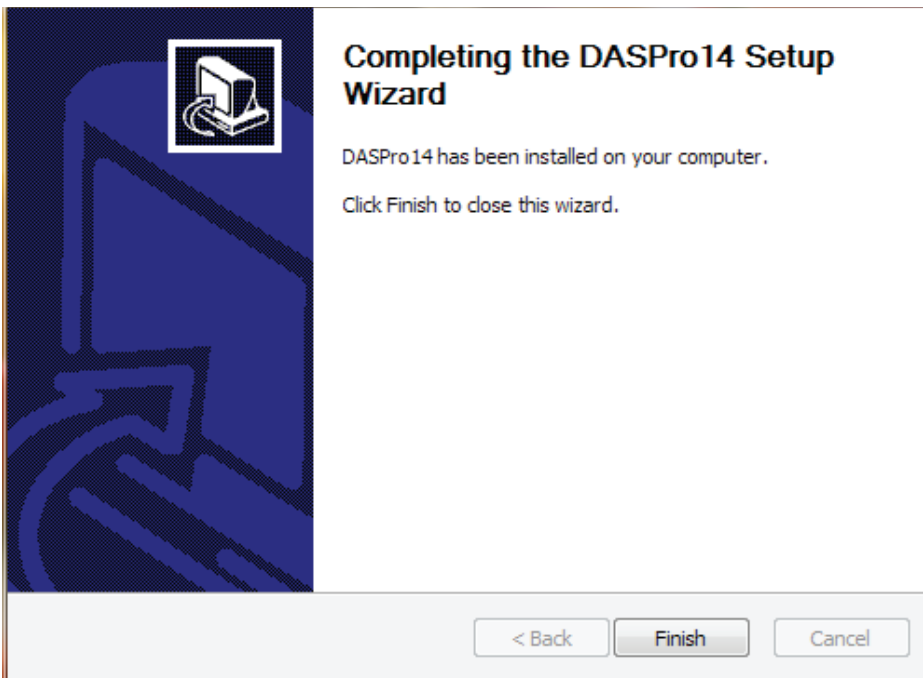

The DASPro14 software is now ready to be registered prior to first use and can be done as follows:

Double-click the link shown below which should be on your PC desktop:



This will then open the following screen:

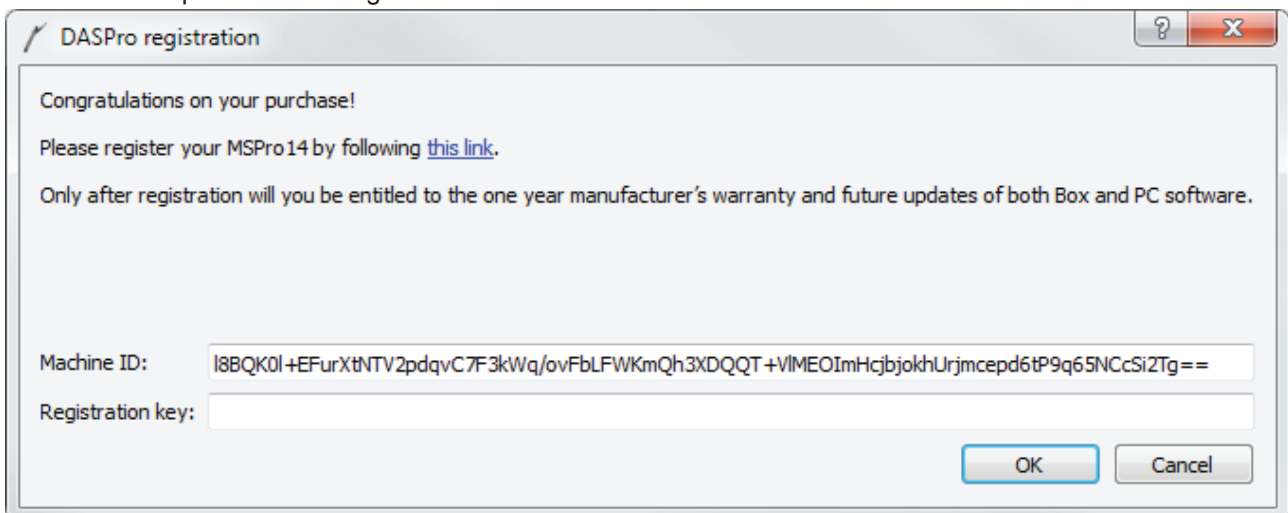

If a registration key is already known, enter it in the appropriate field, else click the link which opens a webpage:

<http://www.morganelectricalmaterials.com/mspro14-registration-form>

Once the necessary fields have been completed the submit button should be pressed and this will automatically send an email to: MSPro14.register@morganplc.com so that a registration key can be sent back to the user.

Once the registration key is received enter it in the appropriate field and press “OK” and the software will open accordingly.

Software update procedure

Software updating will not be done automatically. The procedure for doing this on both PC-software and MPro14 Box is as follows:

- The user will receive an attachment in an email sent to the address used for registering the PC software or is instructed to download it from a specific server.
- Measuring Box:
 - Connect the measuring box to the PC or Laptop.
 - Copy the update file to a specific folder on the measuring box.
 - Disconnect the box from the PC or Laptop.
 - Restart the box to perform the update.
- PC software
 - Follow on-screen instructions as in the initial installation

USING THE MSPRO14 MEASURING BOX

First, connect the sensor to the MSPro14 measuring box then turn the unit on; wait for it to start-up at which point you will see the following screen:



The status bar will show how the loading is progressing and once loaded the Welcome Screen will be displayed.

Welcome Screen



This screen shows both the MSPro14 product ID and box software version.

The symbols on the top of the screen mean the following:

	The size of the memory will be at least 30 Mbyte. This should be enough to store at least 250 datasets.
	Sensor position
	Units currently set on box – either metric or imperial
	Battery life
	Press ok to continue
	Help

Home Screen

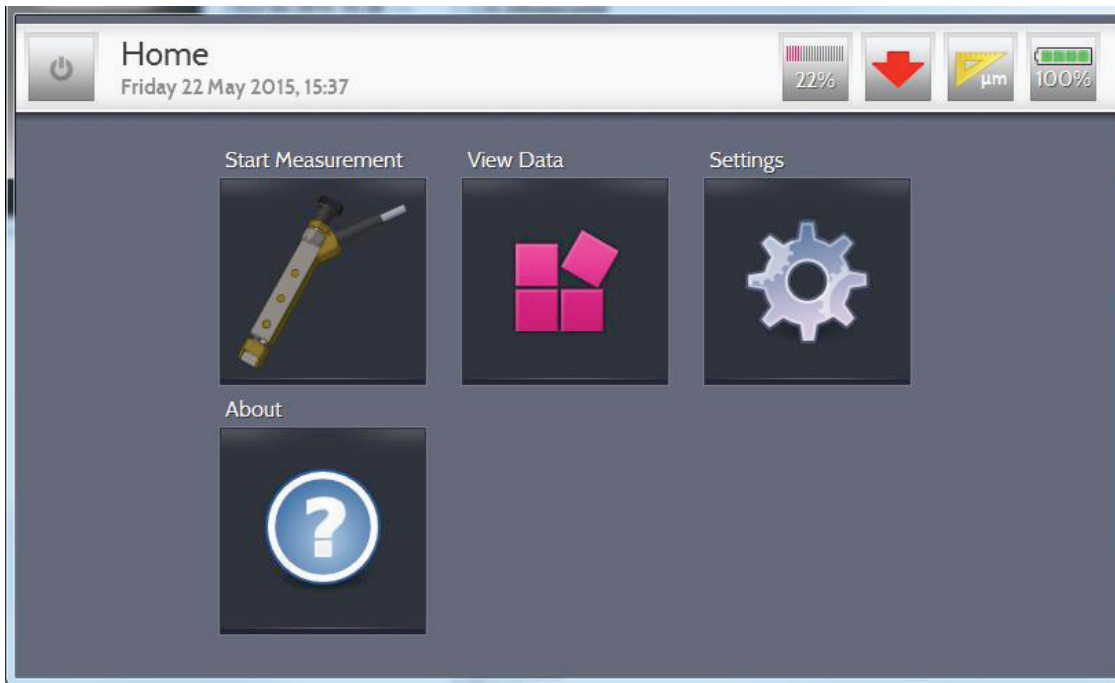

There are 4 options to use:

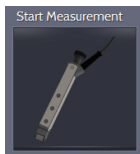

Start Measurement

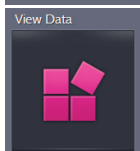

View Data

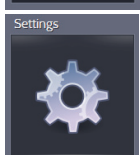

Settings

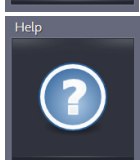

Help

SETTINGS

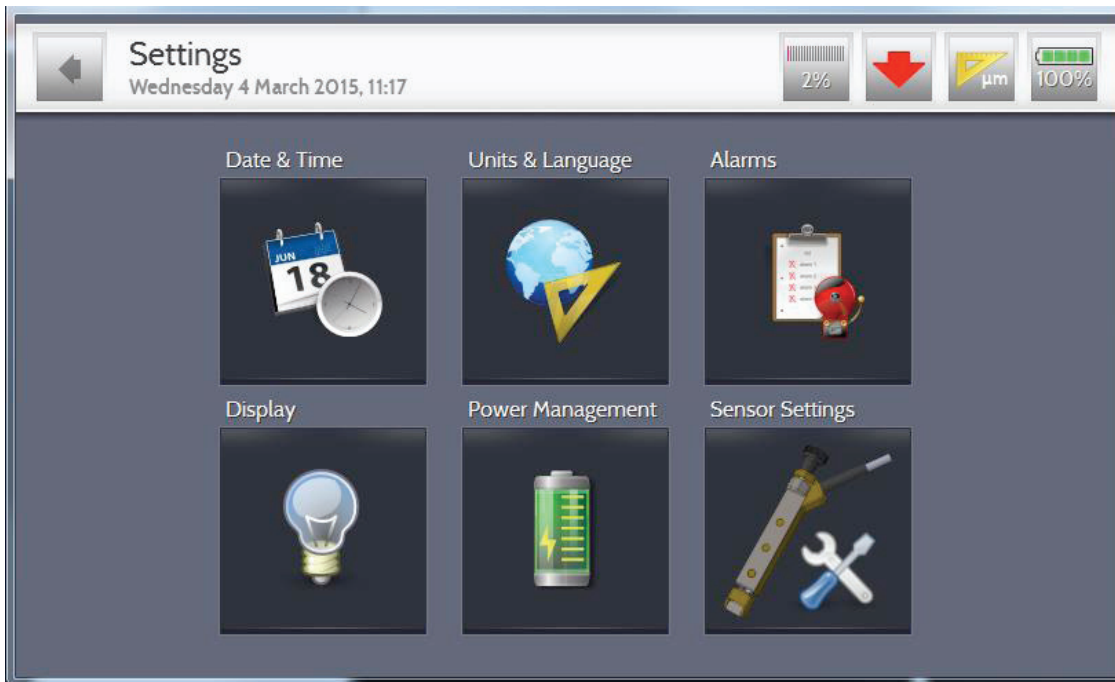

From this screen you can alter 6-off different settings:

Date & Time

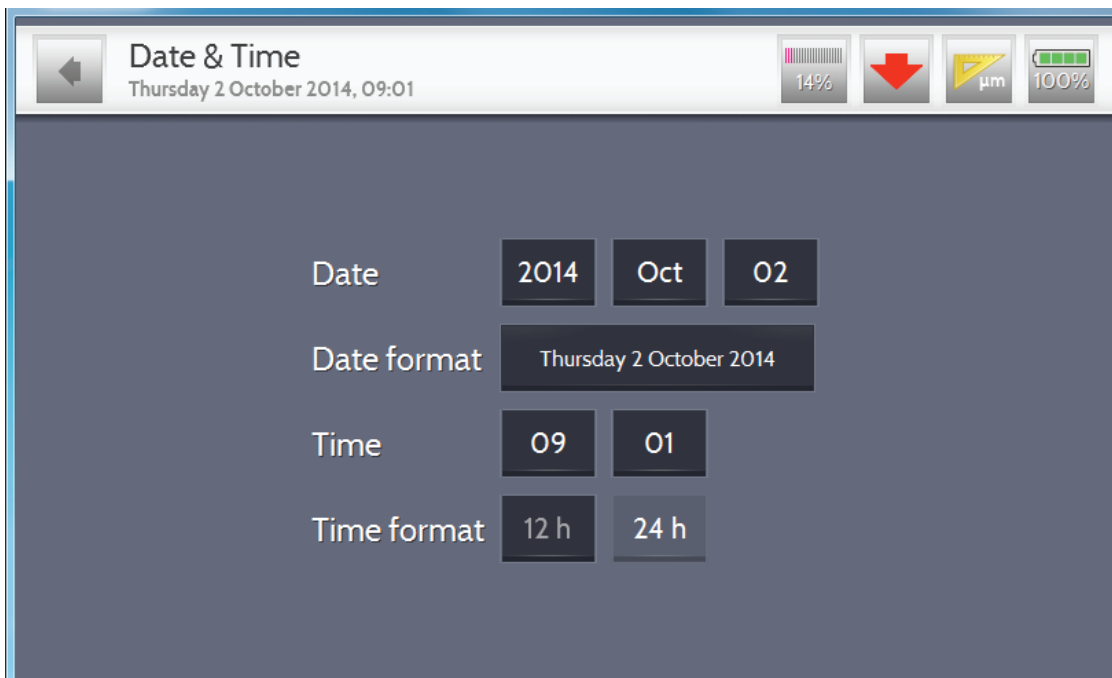

Units & Language

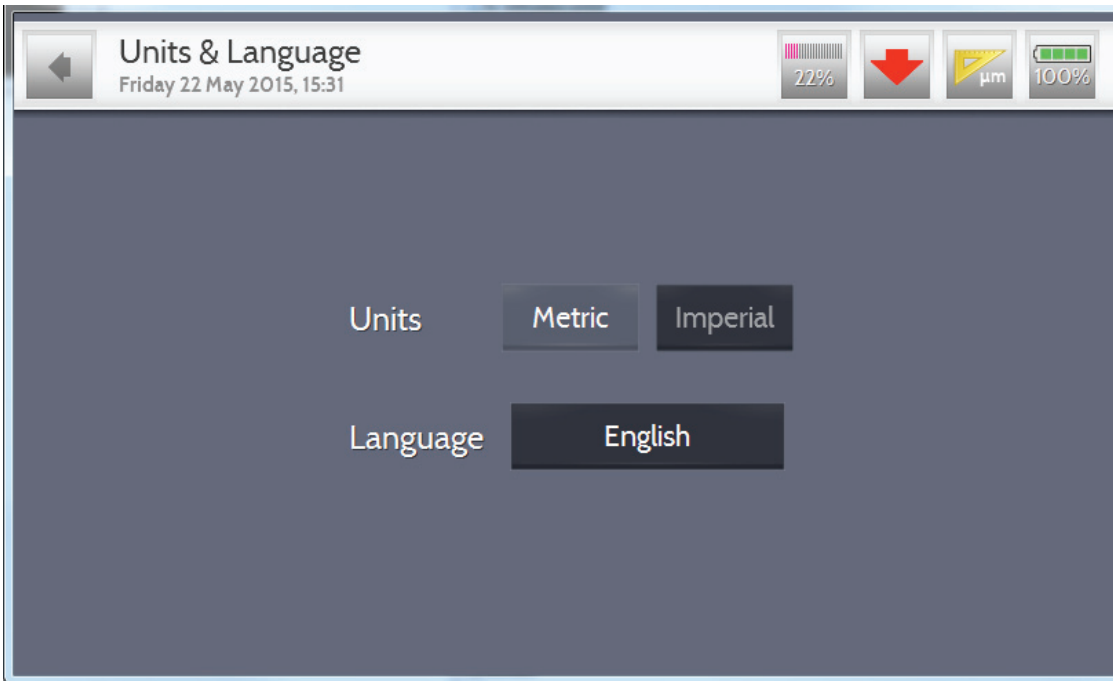

There are 5 different languages to choose from: English, Dutch, French, German and Spanish

Alarms

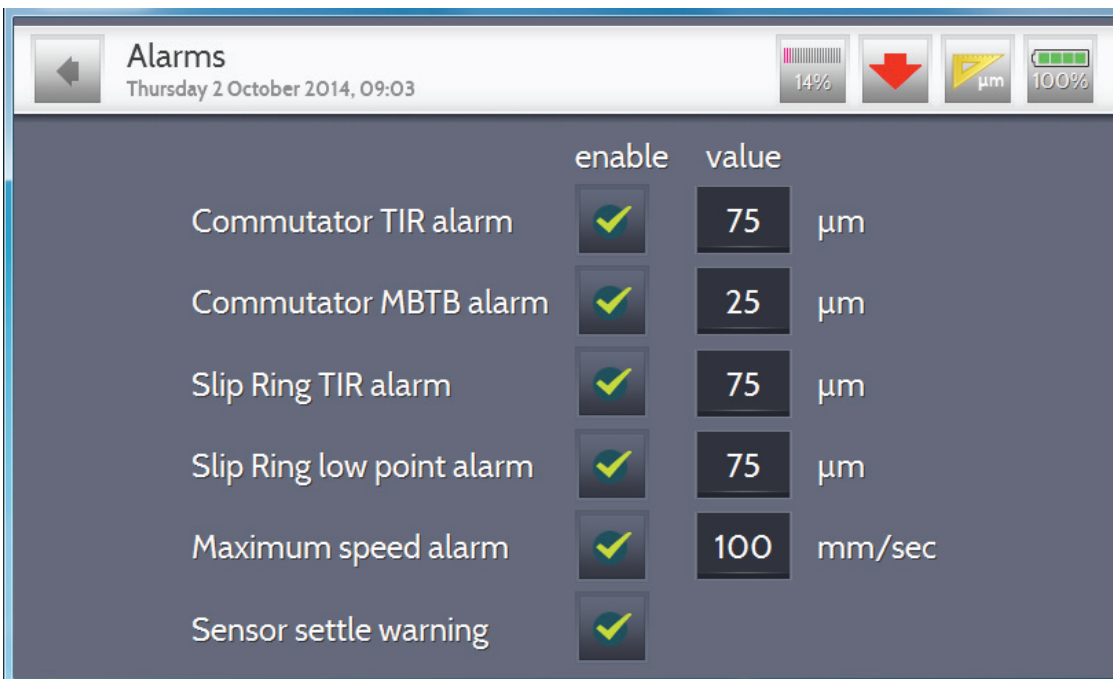

Alarms can be set depending on the tolerances you require

Display

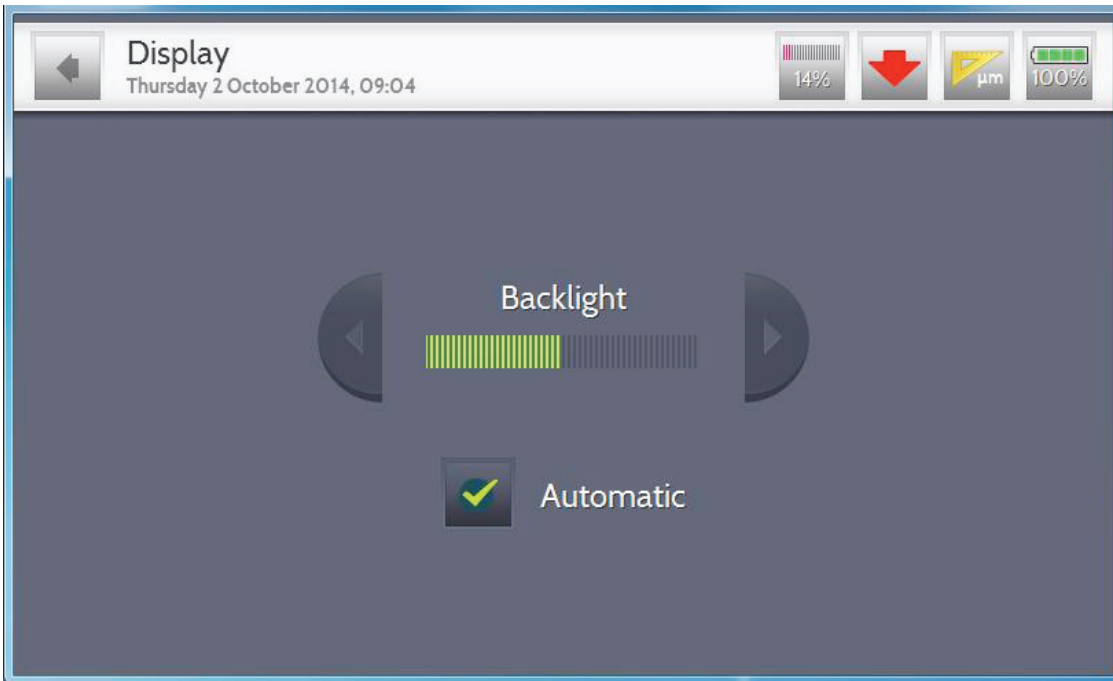

Brightness can be automatic or user defined

Power Management

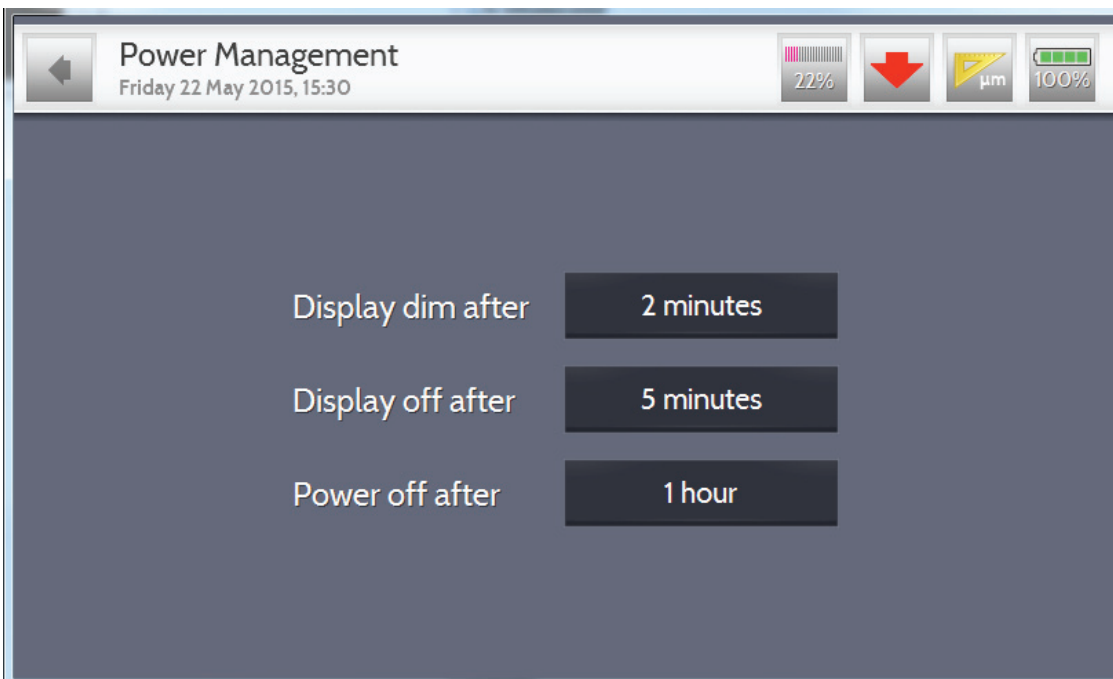

Sensor Settings

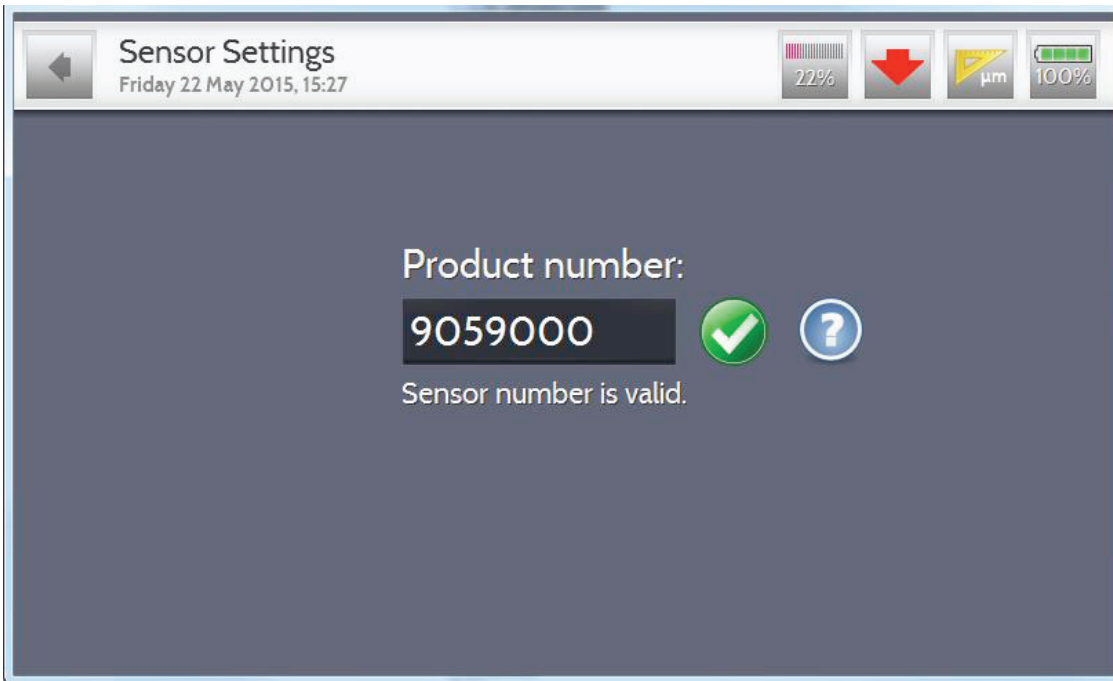

This will display when the sensor number is correct

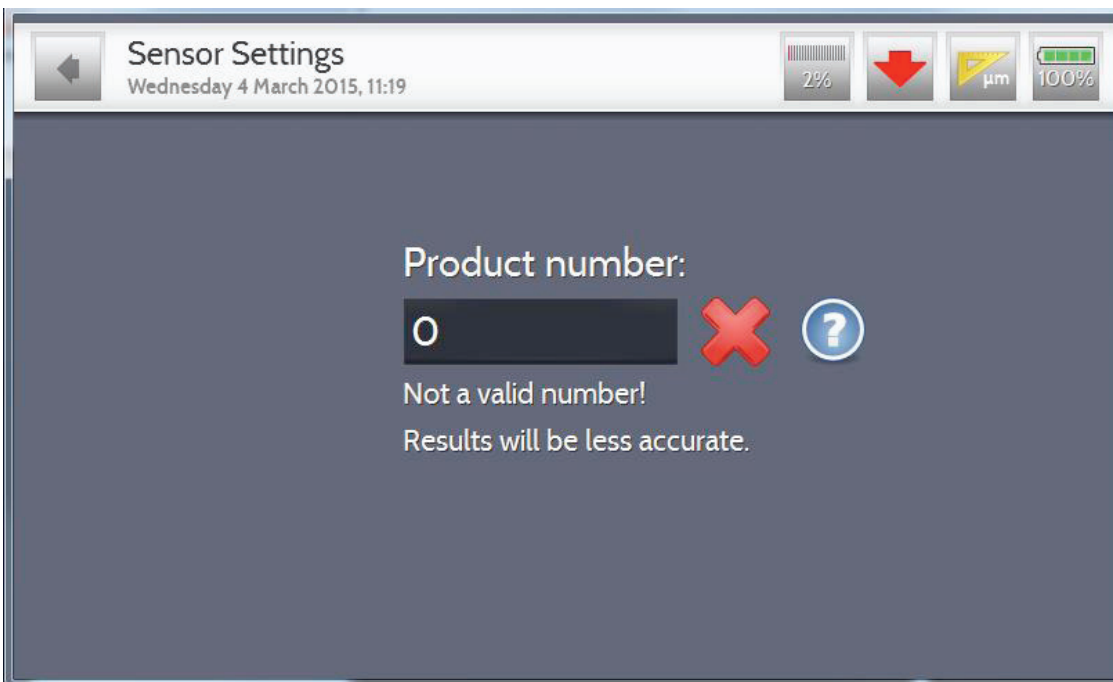

If the sensor number is not valid or entered then this is shown

START MEASUREMENT

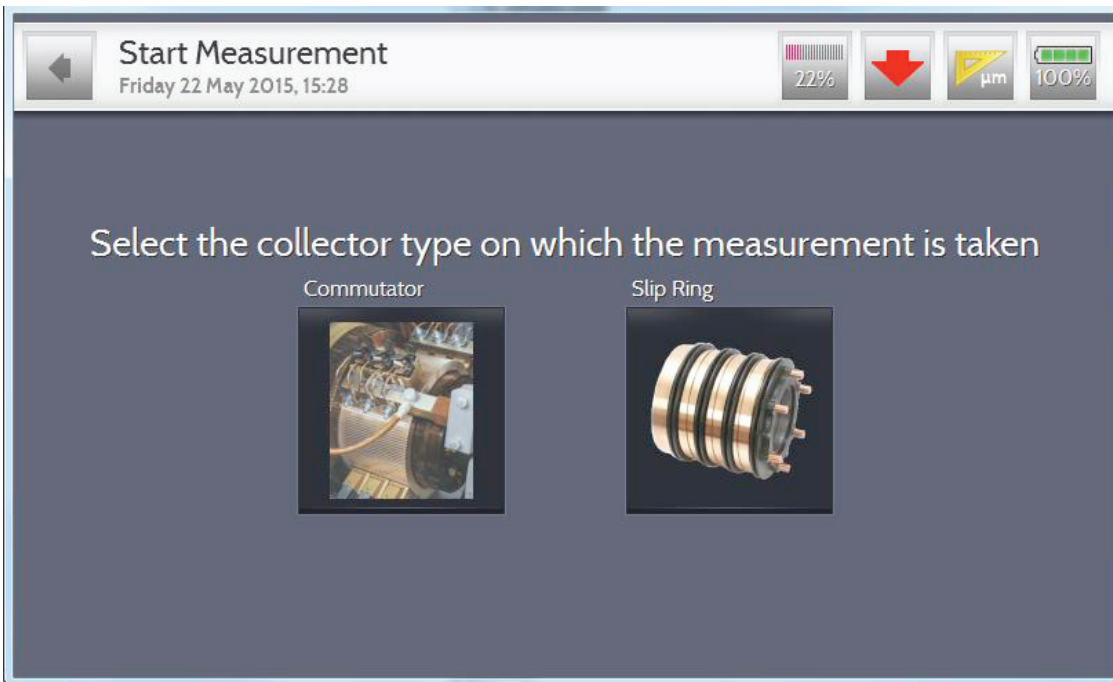

Once you decide to take a measurement you must determine the type of collector on which the profile is being taken, i.e. Commutator or Slip-ring

Commutator

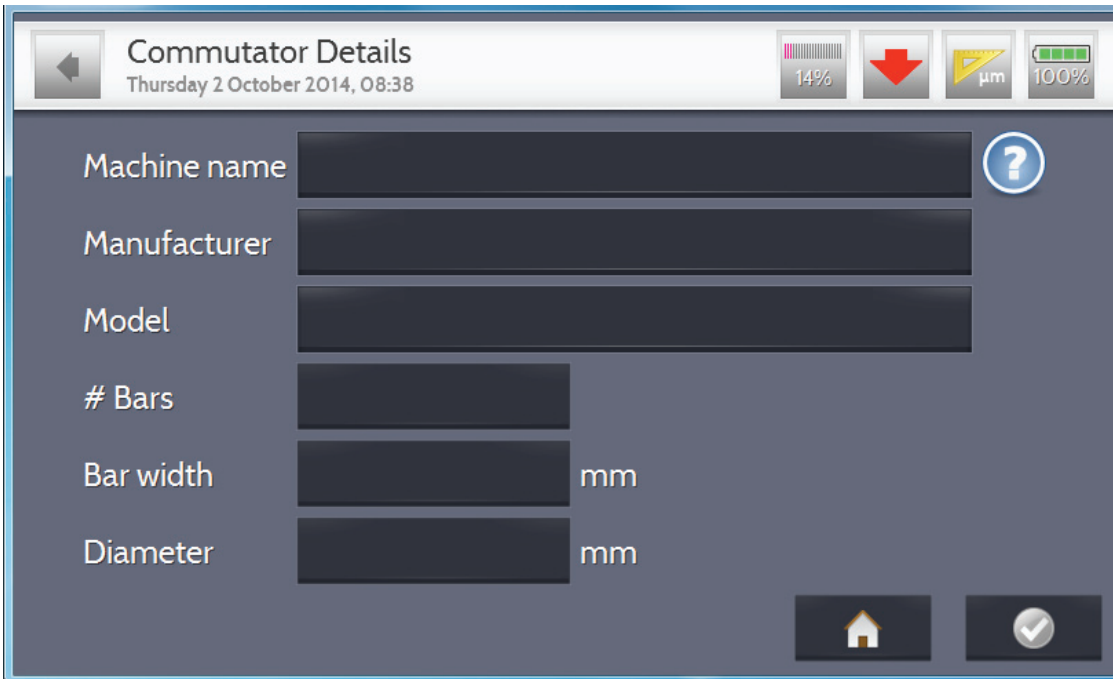

On this screen as much information as possible is to be filled in as it can be used to generate your own company specific machine database, and in order for a machine to be saved in the database the top 3 fields are to be completed:

- Machine Name
- Manufacturer
- Model

Also, if the number of bars is known (diameter can also be entered but is not as accurate on a commutator) then this should be entered as it will mean that the recording will stop automatically rather than the user having to stop the recording manually.

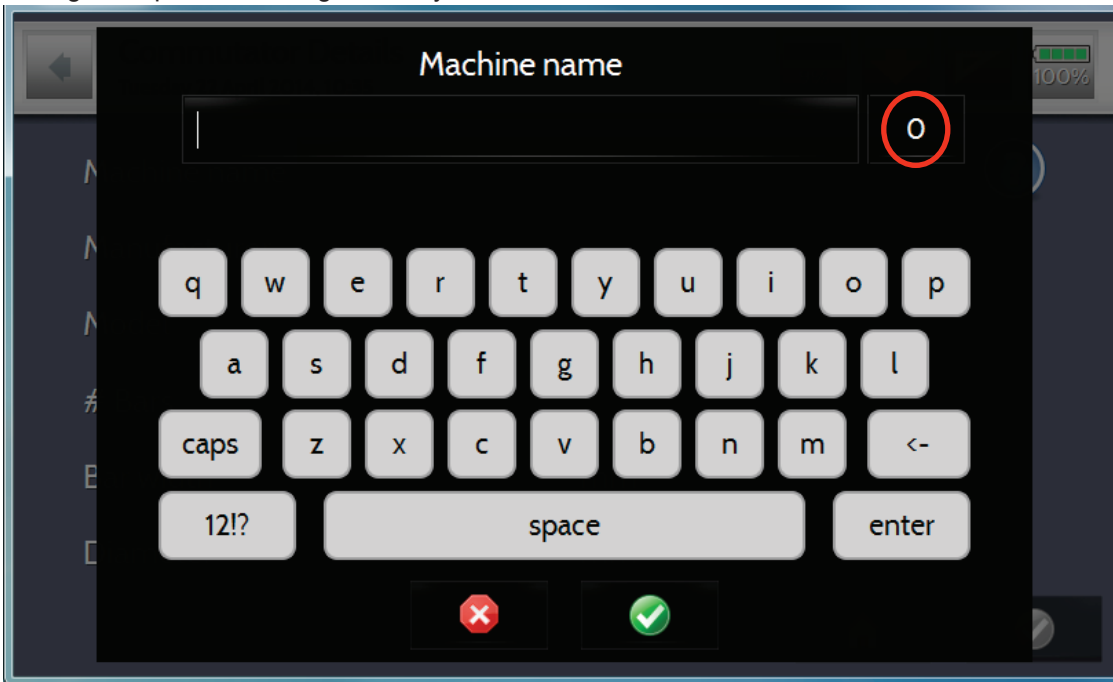

Enter the required information using the on-screen keypad. Note the highlighted '0'; if there are any machines in your database this number will reflect that allowing you to choose the previously entered machines – thus saving re-entering information.

The next screen is used to determine whether you require TIR and MBTB alarms, and if so, the value at which it is triggered; note that the default is that which is set on the Alarms page previously described.

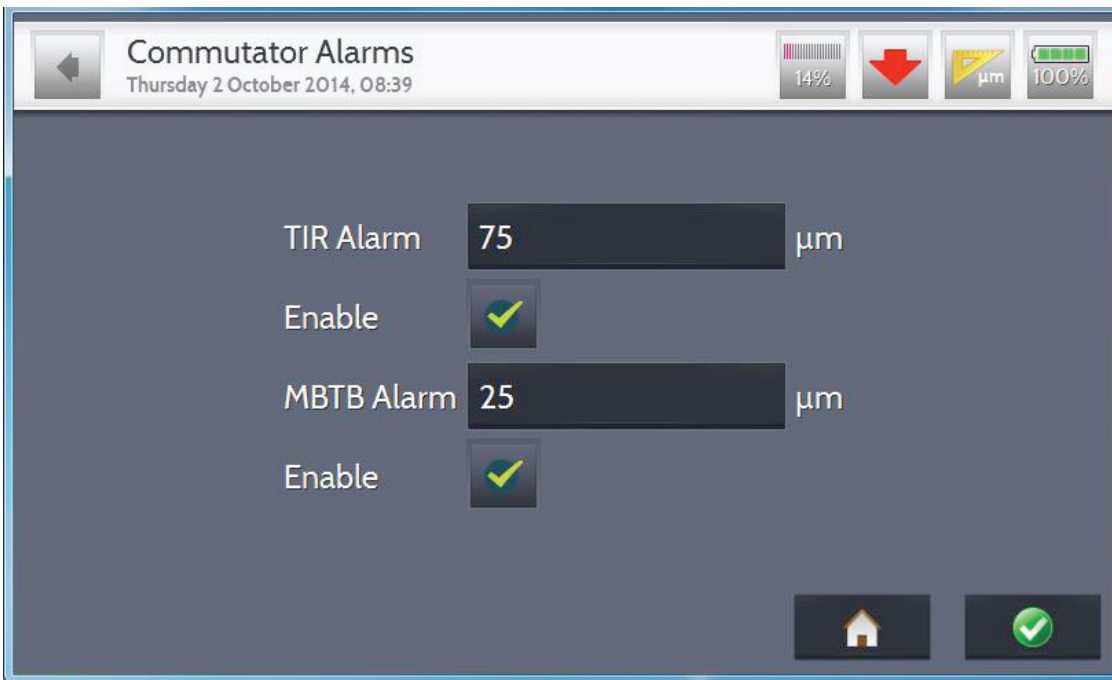

Setting the Sensor

The sensor has been designed so that for the greatest measurement range the sensor head should be positioned mid-way through its travel, i.e. 3mm (118mil) in real terms, out of a possible 6mm (236mil). The ideal displacement is 0.00mm (0mil) however anywhere between $\pm 0.2\text{mm}$ ($\pm 8\text{mil}$) can be used as a start point. In order to fit the sensor the following needs to be done:

- Loosen the clamp knob counter-clockwise so that the clamp is as flat as possible.
- Fit the sensor into the chosen empty brush box or sleeve along with any required packing pieces (or custom made holder) but do not tighten fully at this stage. Care should be taken to ensure that the sensor is fitted as square as possible in the brush box and if a commutator is being profiled (ideally) in the centre of a bar not in the gap between bars.
- The sensor must be located in the brush box so the display reads $\pm 0.2\text{mm}$ or $\pm 8\text{mil}$ or less; this will be highlighted by the screen displaying either red, amber or green icons – with appropriate text accompanying the icon:

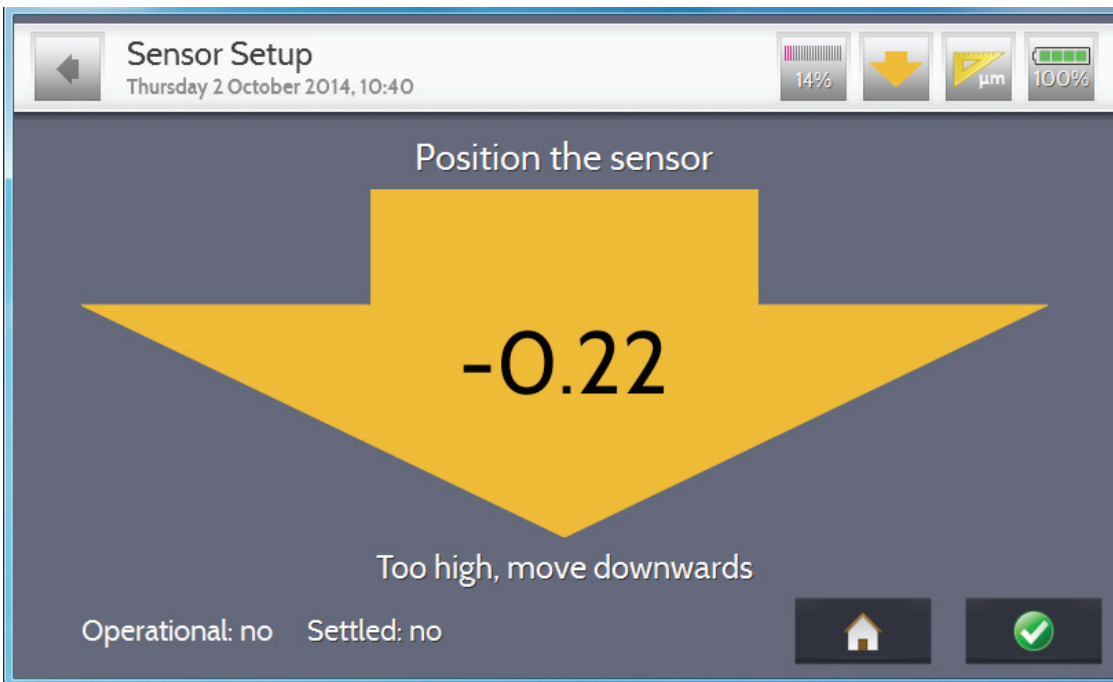
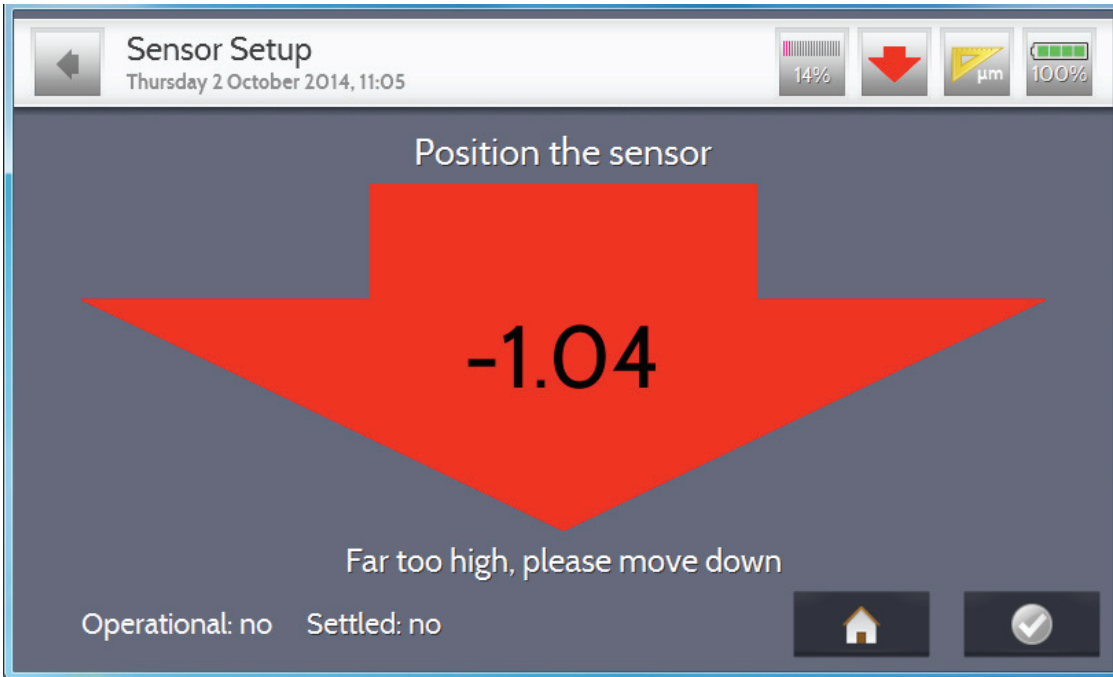

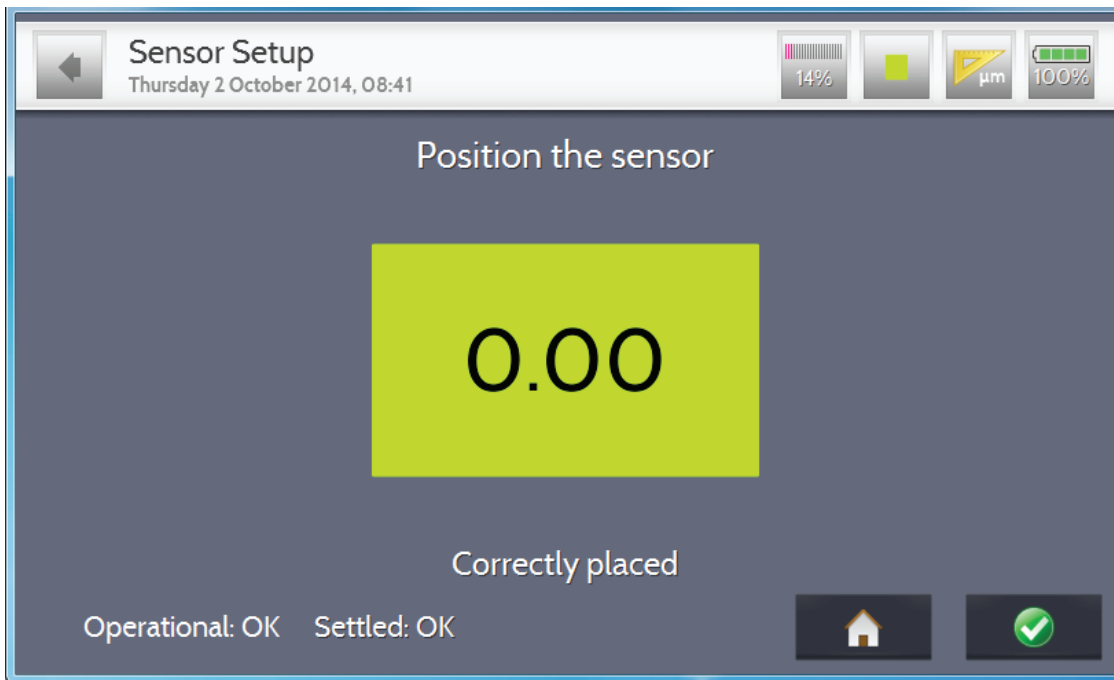

- When the sensor head is in position (ideally the display will be green), tighten the clamp in the holder or sleeve fully so that there is no movement from the sensor. Only hand tighten the sensor and do not use any tools or other equipment (as over tightening may damage the clamp).
- Mark the collector surface so that a reference start/stop point can be located
- Next, the collector needs to be rotated in the direction in which the profile will be taken in order to stabilise the sensor; if a full rotation is not possible then the collector must be rocked back and forth slightly – note that for consistent results the last movement must be in the same direction as that in which the profile will be taken. Note that the 'Operational' and 'Settled' flags (on bottom left hand side of the screen) will change to 'OK' once this has been carried out correctly.
- Check the display still reads $\pm 0.2\text{mm}$ ($\pm 8\text{mil}$) or less and if you are measuring a commutator also ensure that the sensor is still located approximately in the middle of the marked bar
- It is possible to continue when the sensor has not been placed correctly, i.e. **when the arrow is orange** however an additional warning appears advising you of the issue.

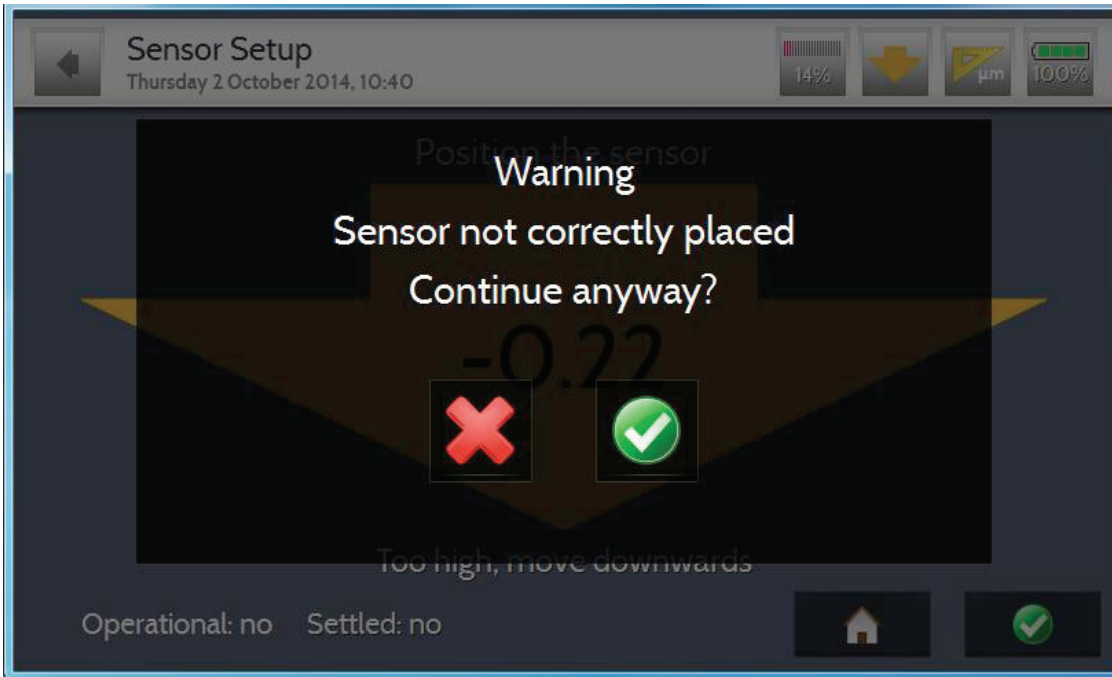

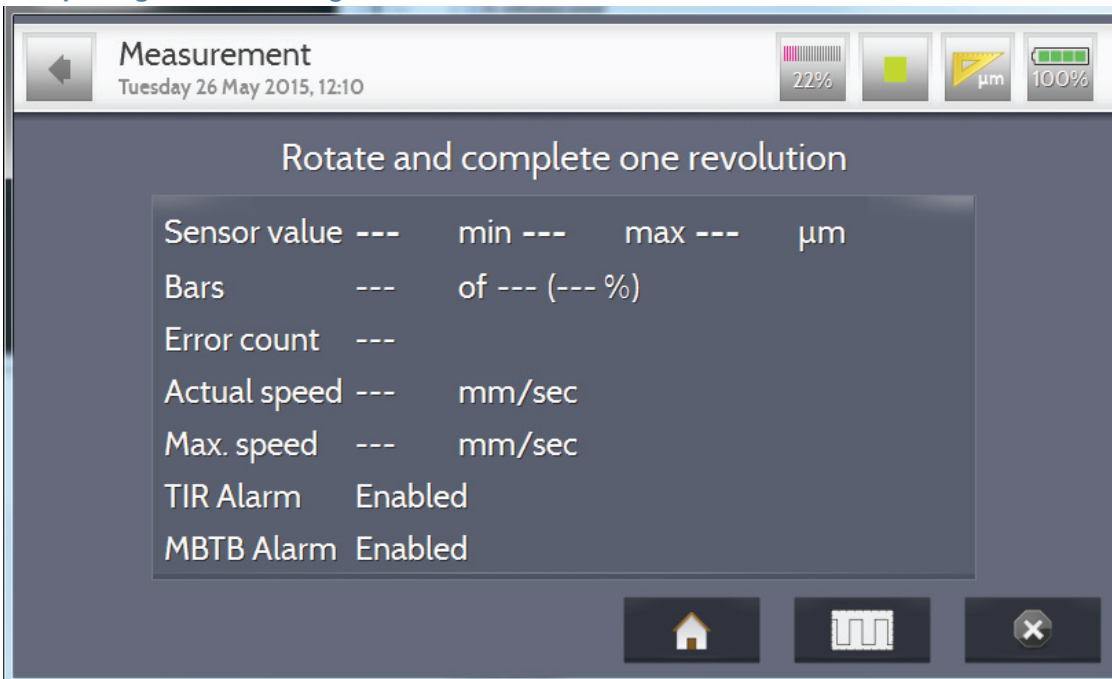

Completing one Recording



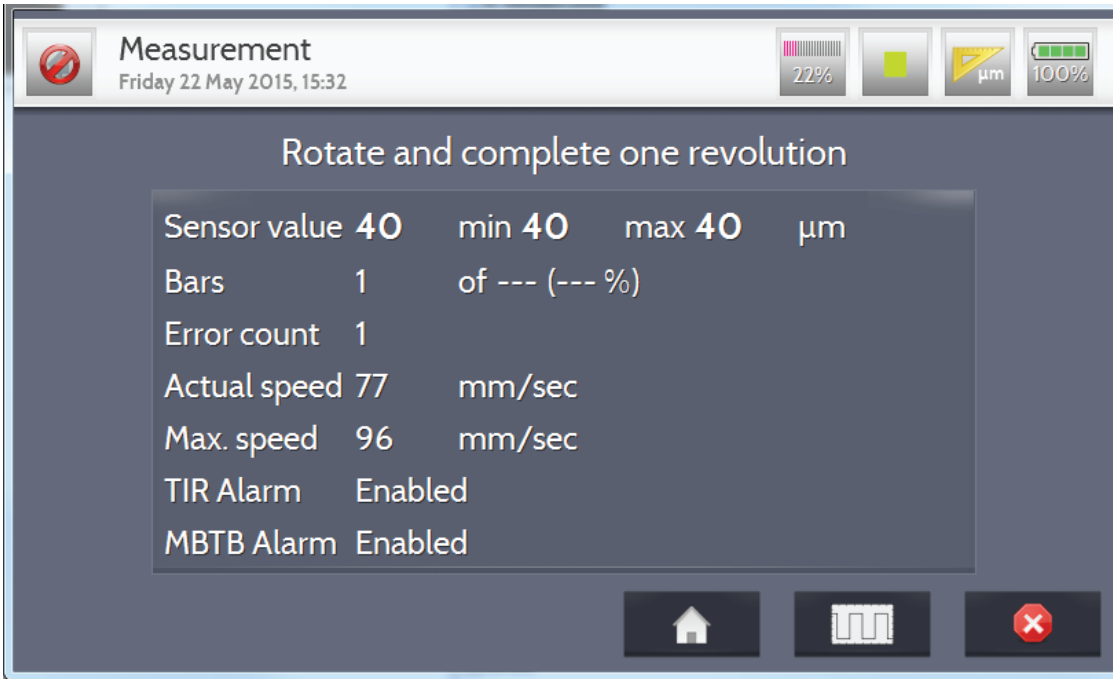

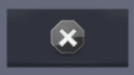
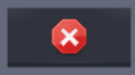
The collector should be rotated and the unit will start taking recordings



When rotation is detected the  will change to ; the recording will stop automatically if

the number of bars (or diameter) was entered, else  will have to be pressed.

It is possible to alter the way the readings are displayed by pressing the  or  button; this will alternate between text or a real-time linear graph.

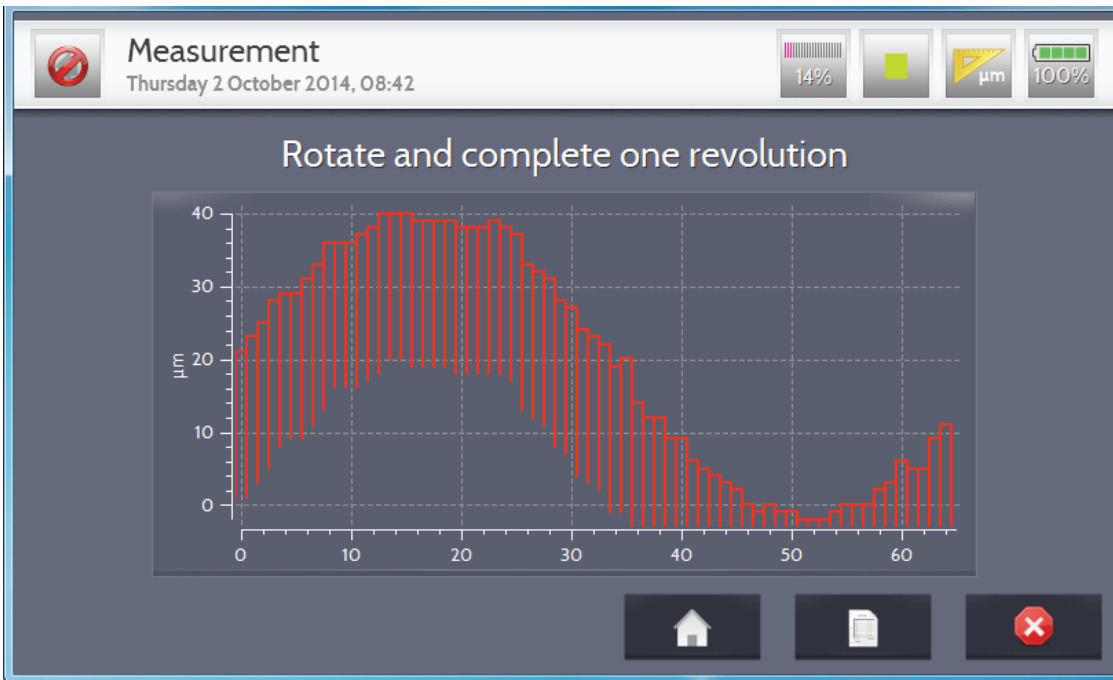

On completion of the recording, the following summary page is displayed:

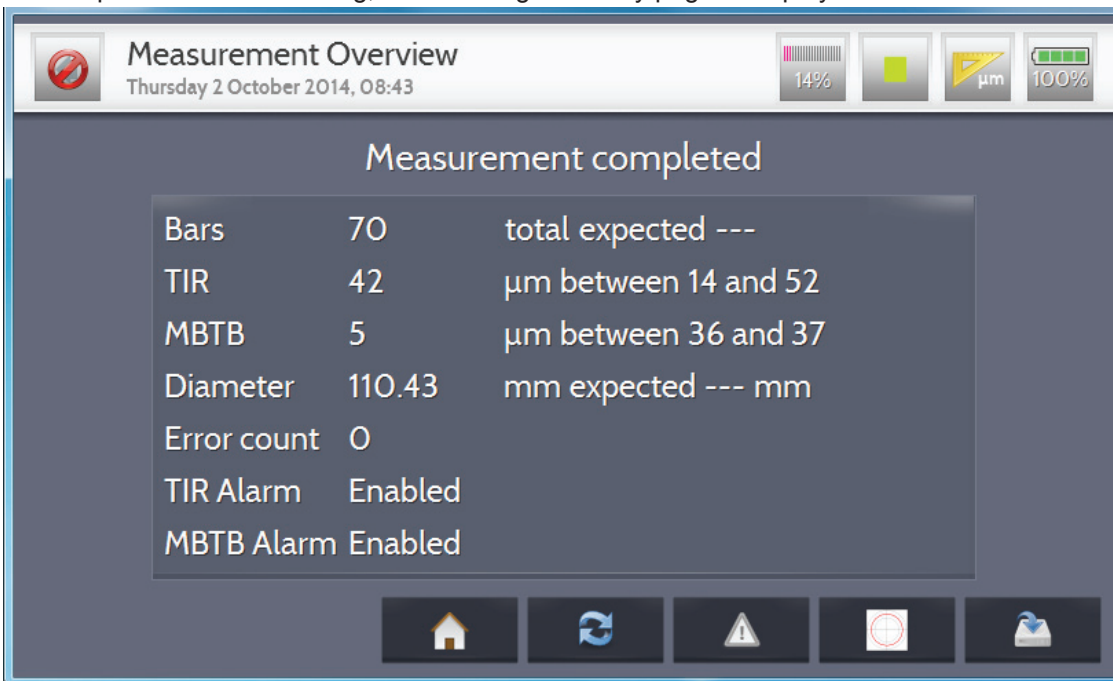

The symbols on the bottom of the screen mean the following:

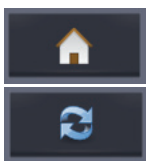

Return to home screen without saving

Re-take recording, therefore deleting existing one



View alarms/errors – if this symbol is highlighted in red

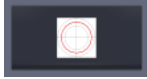

View radial plot

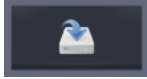

Save recording

If there are any alarms triggered/errors they will be displayed as follows:

Bar No	Length	Description
0	3	Overspeed: 107 mm/sec
1	13	High mica indication: -23 μm
5	4	Overspeed: 107 mm/sec
15	2	High mica indication: -23 μm
16	3	Overspeed: 137 mm/sec
18	18	High mica indication: -21 μm
21	1	Overspeed: 107 mm/sec
22	7	Overspeed: 107 mm/sec

The screenshot also shows a toolbar with a back arrow, a battery level indicator at 14%, a red downward arrow, a yellow ruler icon labeled μm , and a battery level indicator at 100%. On the right side of the table, there are three buttons: an upward arrow, a downward arrow, and a green checkmark.

The radial plot button allows the user to have an overview of the general shape – and zoom in and out.

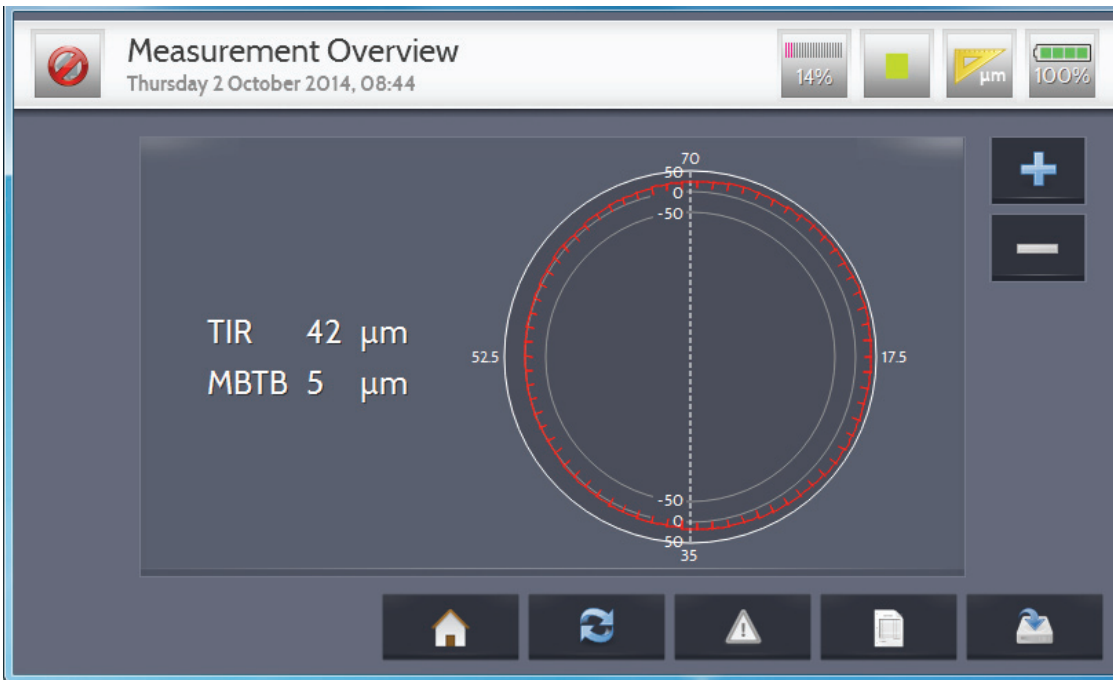

If the user wants to save the recording, the following screen is displayed:

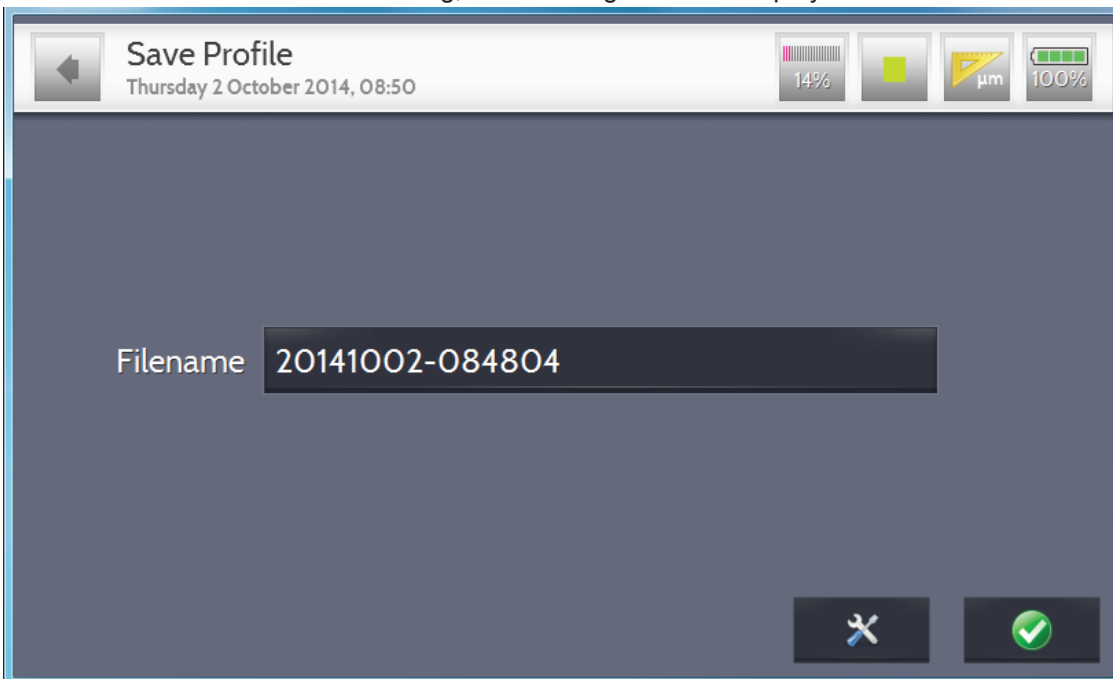

The default filename is in the format: year/month/day-hour/minute/second – hence it will be totally unique; this filename can be over-written and/or modified if desired.

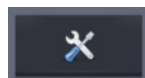

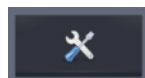
In order to add the machine details into the database, the  button must be pressed – provided the machine information is not already in the database, unless the user wants to update the existing data with the latest reading(s).

	Actual		Database
Manufacturer	Tect Inc		
Model	D1		
# Bars	4	→	
Bar width	3.9 mm	→	
Diameter	6.17 mm	→	

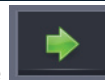



The information can be transferred into the database by pressing the button.

Filename
20141002-084804

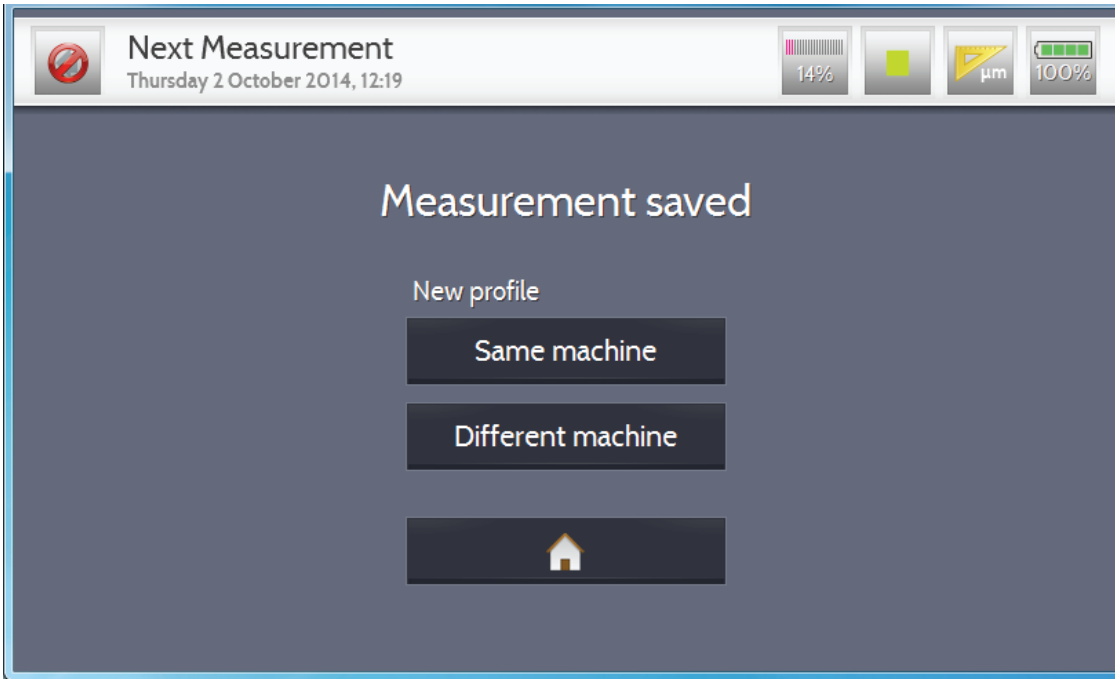

Once the user wants to save the recording, the button must be pressed. This will then lead to the following options:

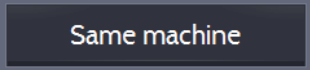
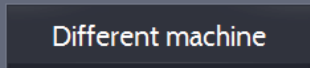

- | | |
|---|--|
|  | Same Machine returns the user to the sensor setup |
|  | Different Machine returns the user to the Start Measurement screen |
|  | Return to home screen |

Slip-ring

Slip Ring Details
Thursday 2 October 2014, 08:52

Machine name

Manufacturer

Model

Diameter mm

On this screen as much information as possible is to be filled in as it can be used to generate your own company specific machine database, and in order for a machine to be saved in the database the top 3 fields are to be completed:

- Machine Name
- Manufacturer
- Model

Also, if the diameter is known then this should be entered as it will mean that the recording will stop automatically rather than the user having to stop the recording manually.

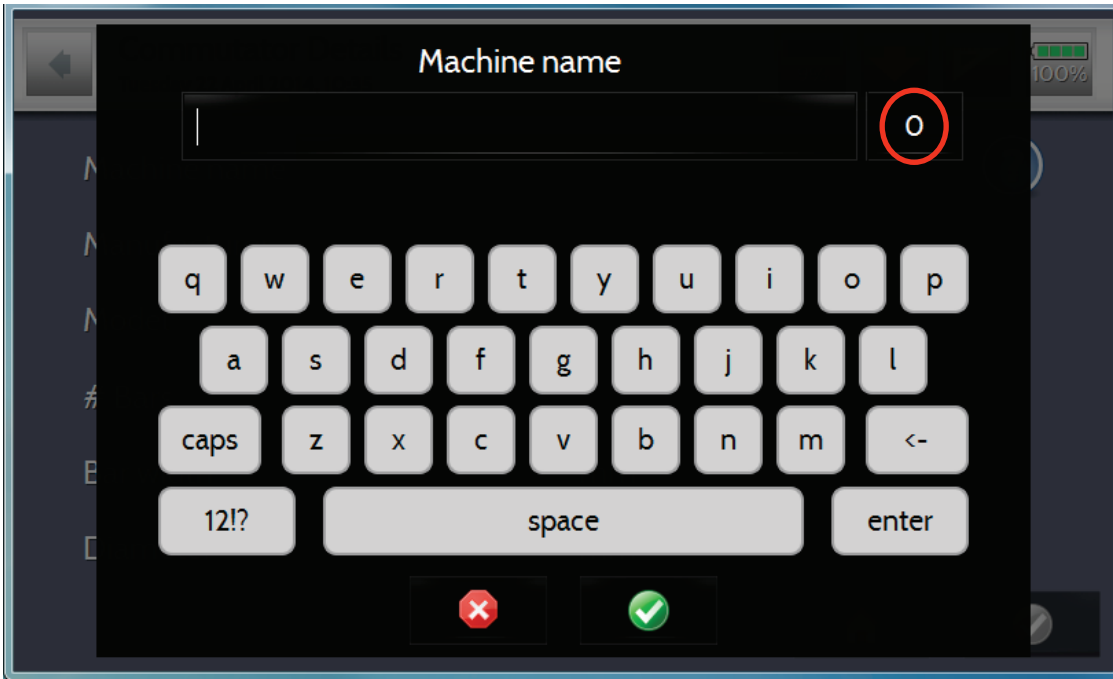

The next screen is used to determine whether you require TIR and Low Point alarms, and if so, the value at which it is triggered; note that the default is that which is set in the Alarms page.

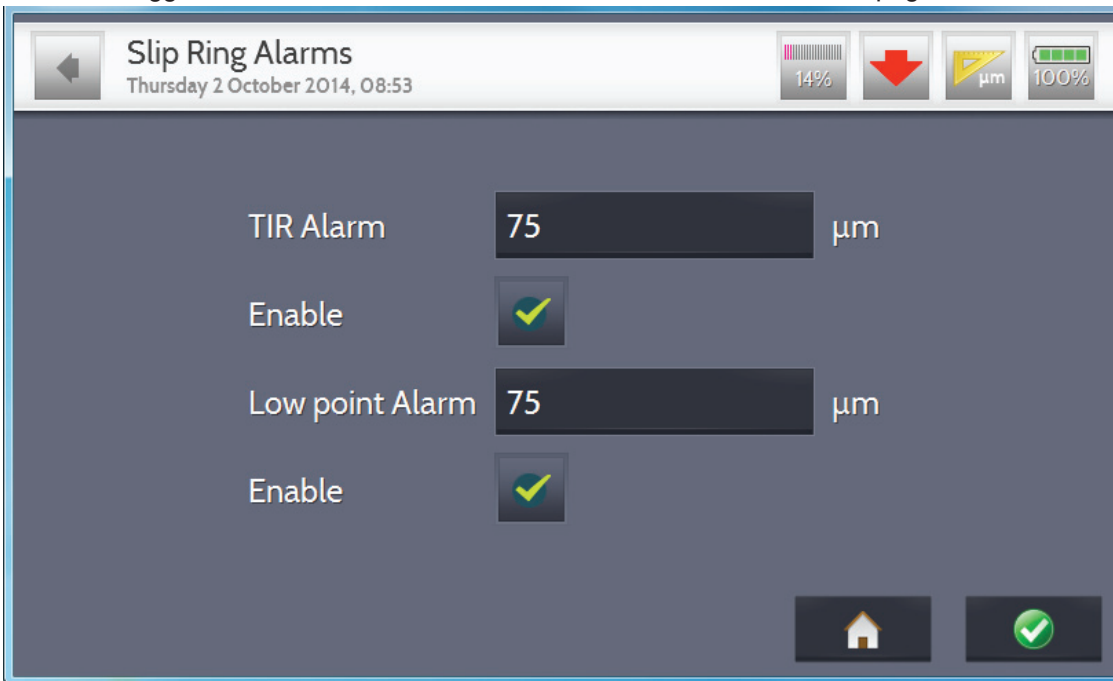

Setting the Sensor

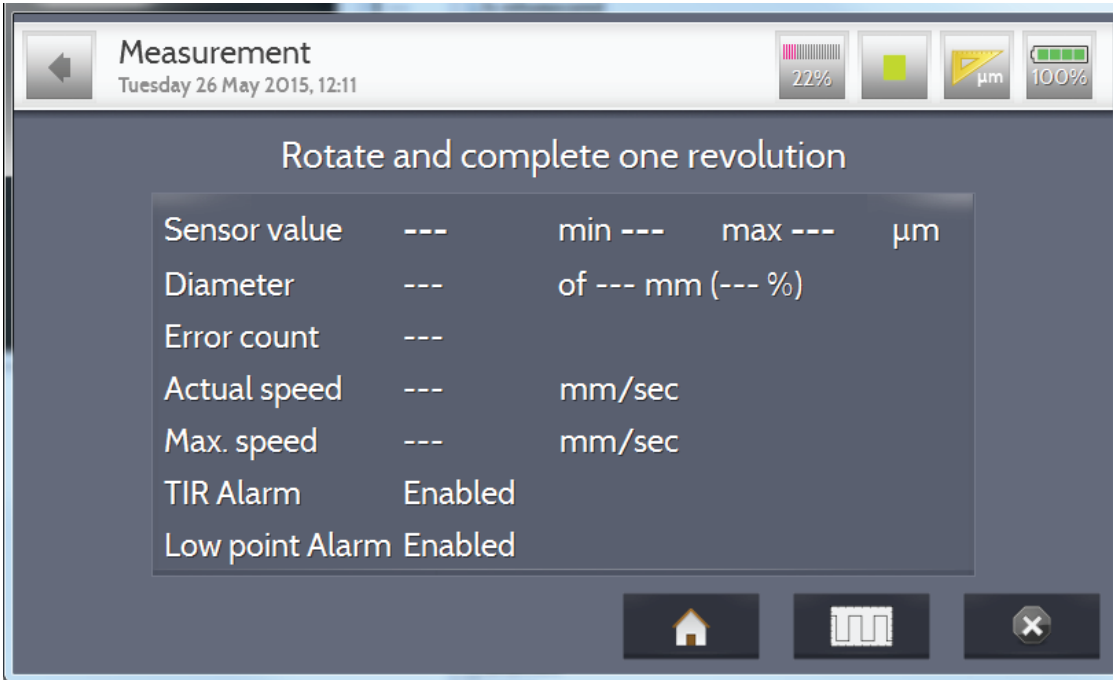

Set the Sensor in the same way as that described for a Commutator.

Completing one Recording

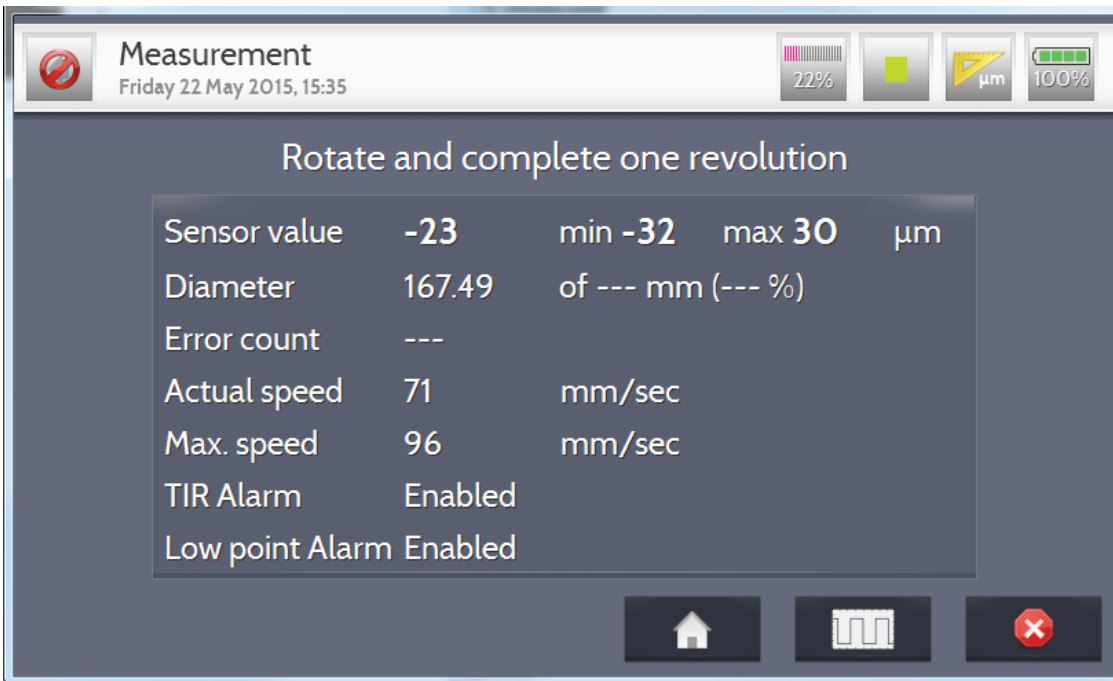

The collector should be rotated and the unit will start taking recordings

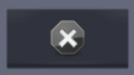
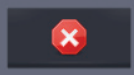

When rotation is detected the  will change to ; the recording will stop automatically if the diameter was entered, else  will have to be pressed.

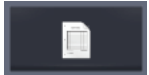

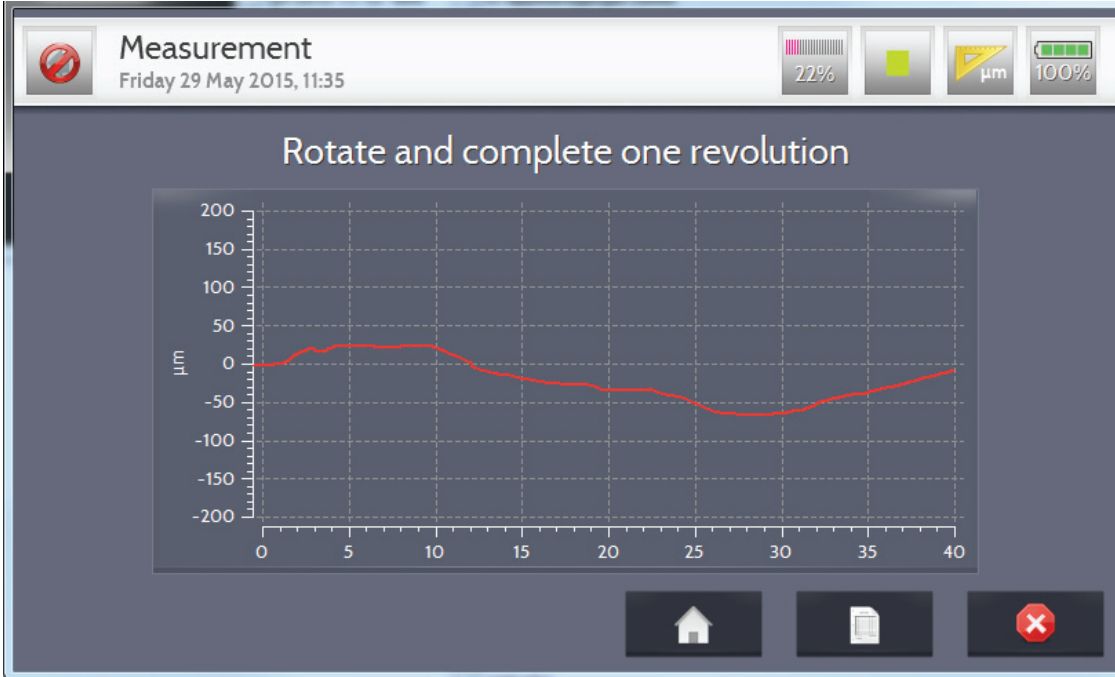
It is possible to alter the way the readings are displayed by pressing the  or  button; this will alternate between either text or a real-time graph.

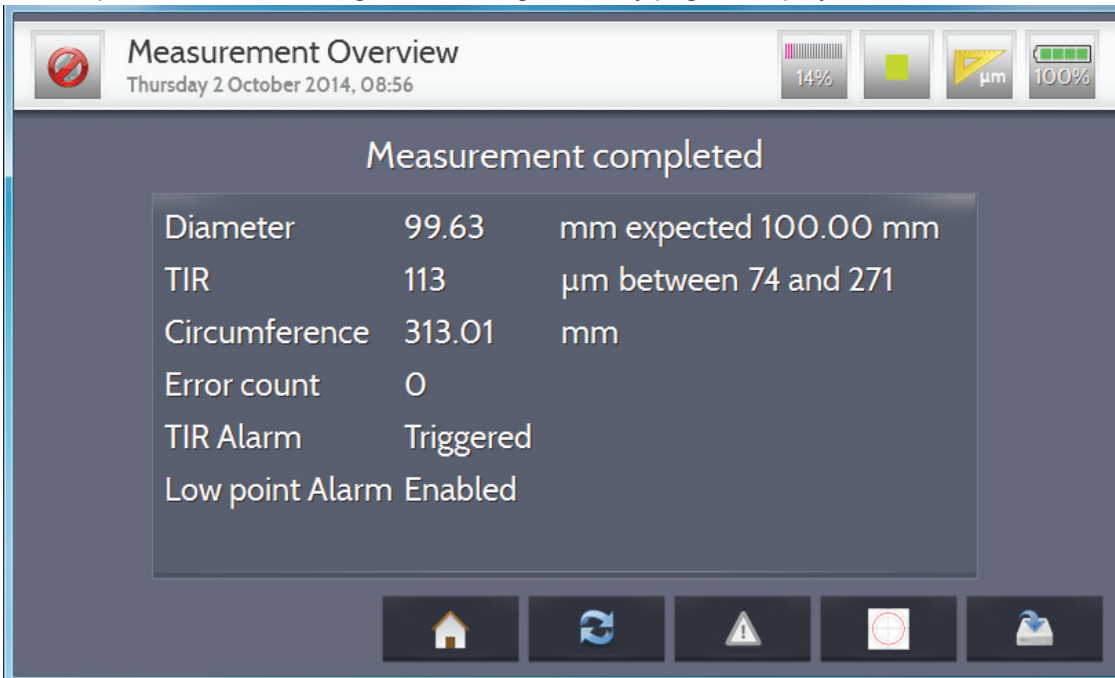

On completion of the recording, the following summary page is displayed:

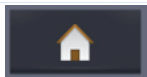
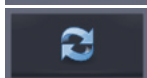

The symbols on the bottom of the screen mean the following:

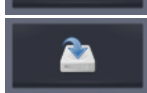
-  Return to home screen without saving
-  Re-take recording
-  View alarms/errors – if this symbol is highlighted in red
-  View radial plot
-  Save recording

If there are any alarms triggered/errors they will be displayed as follows:

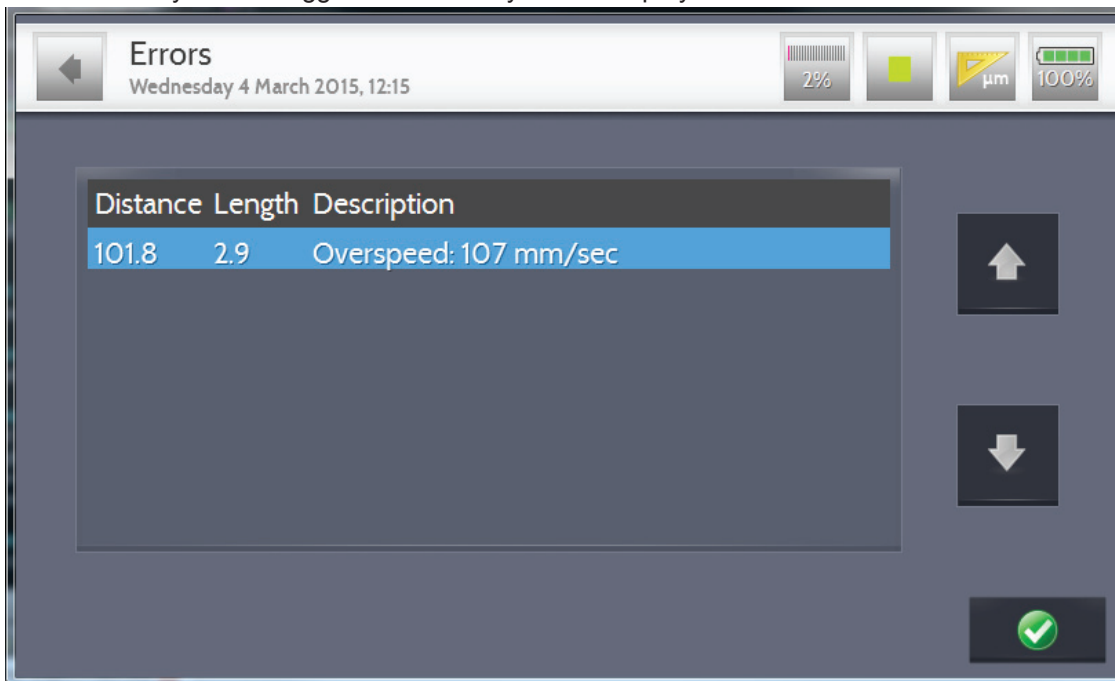

The radial plot button allows the user to have an overview of the general shape – and zoom in and out.

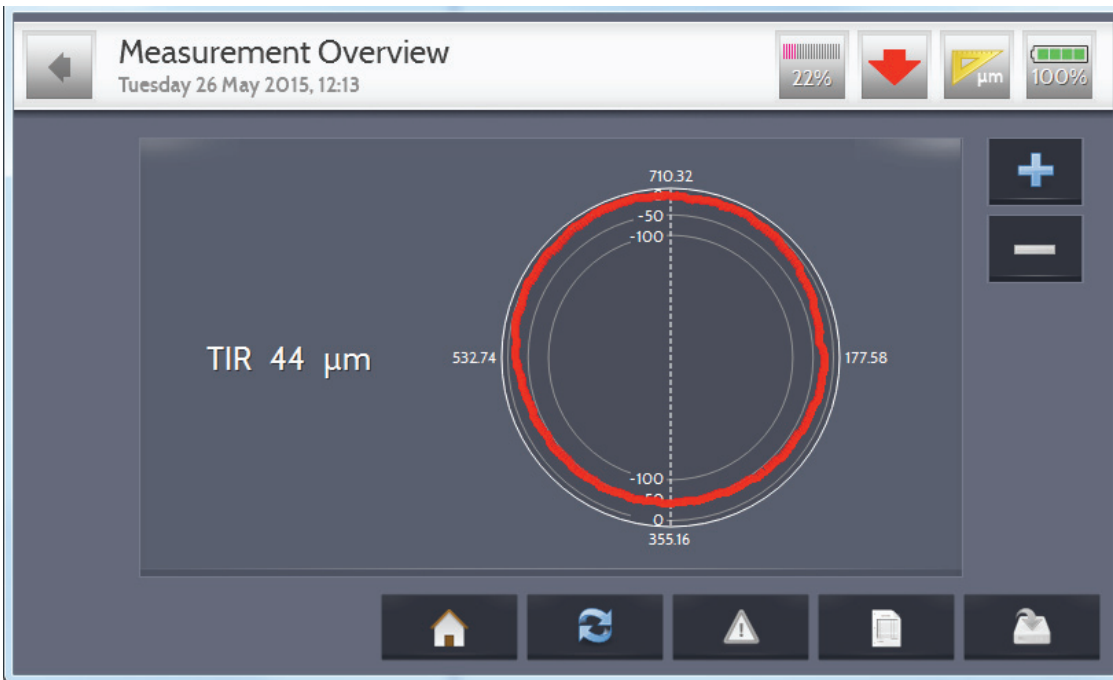

The results can be saved in exactly the same way as that described in the Commutator section.

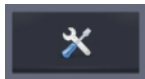
In order to add the machine details into the database, the  button must be pressed – provided the machine information is not already in the database, unless the user wants to update the existing data with the latest reading(s).

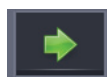

The information can be transferred into the database by pressing the button and saved as previously described.

VIEW DATA

When the user wants to view previously taken collector readings, the following screen will be displayed:

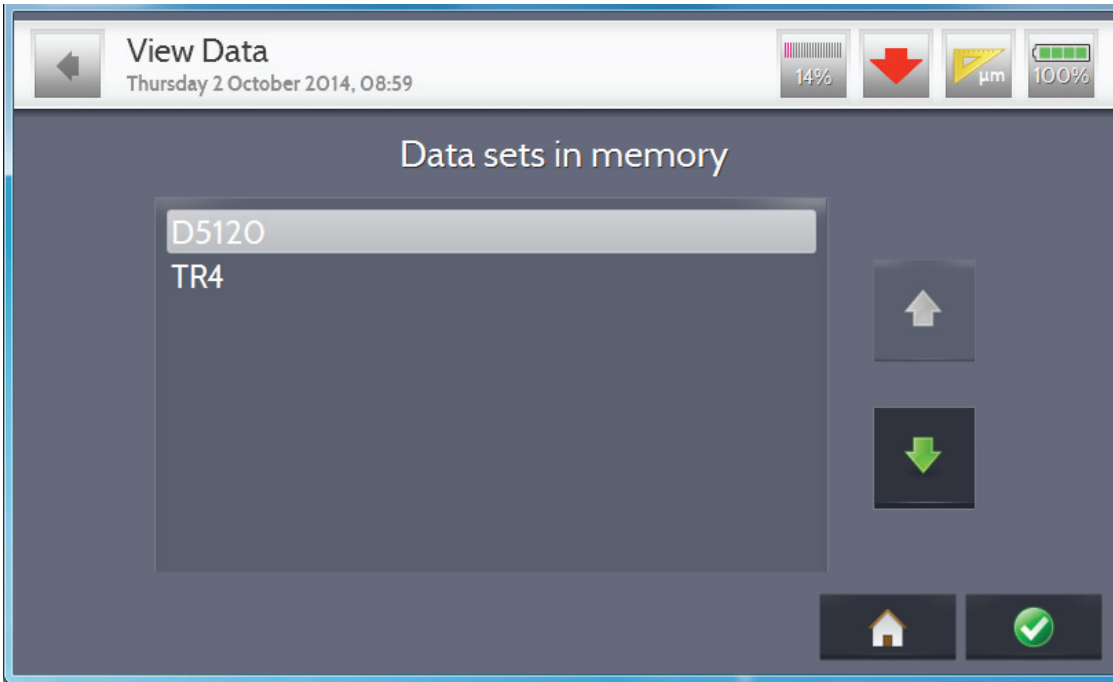

Scrolling through the data sets can be achieved by using the arrows on the side of the screen.

When the required data set is located, the  button should be pressed. This will then show the individual recordings taken for on each machine:

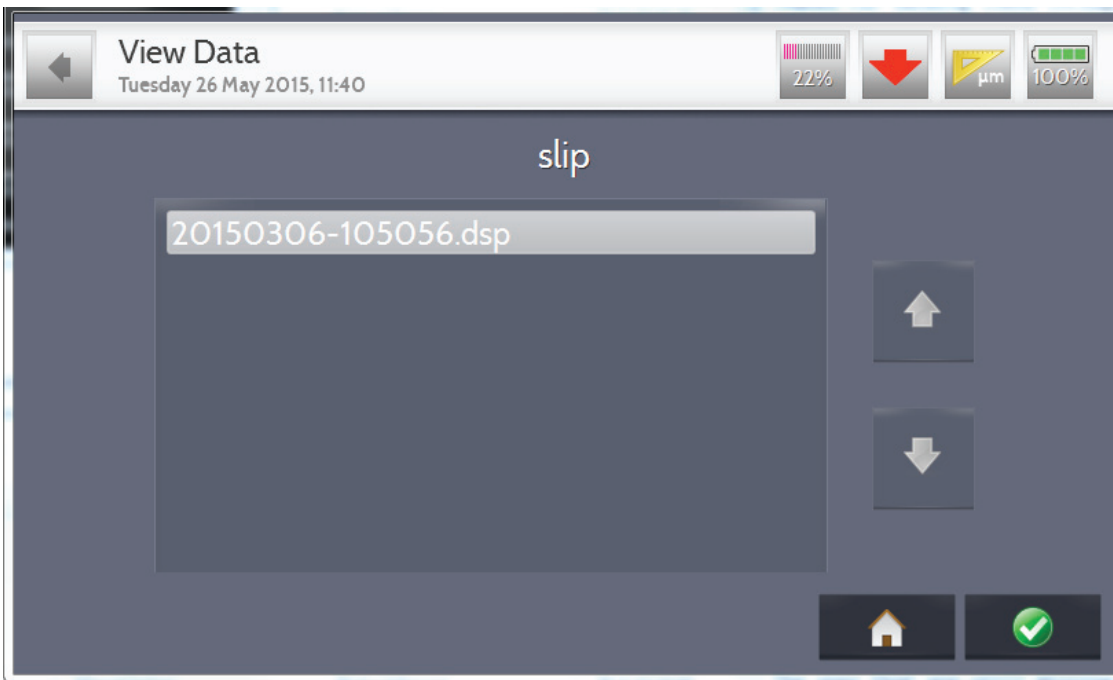

Once the required recording is located the  button is again pressed to continue; this will then display the same screen as that displayed following the completion of the recording, i.e.:

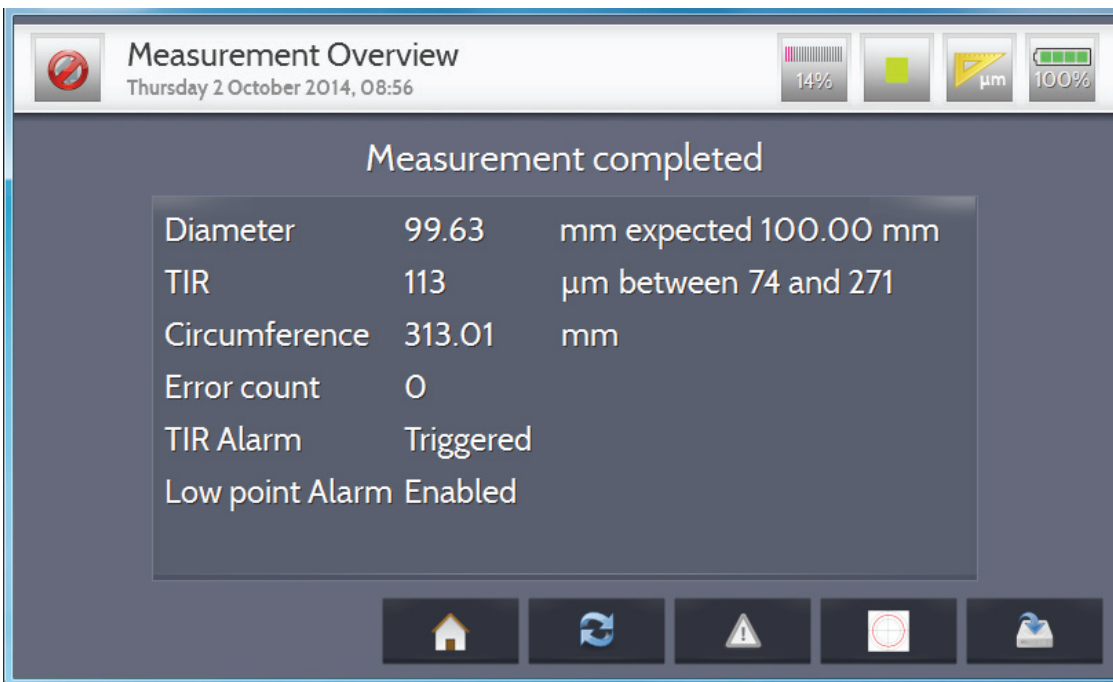

The different icons can be selected as previously described.

Standby Screen

On the main menu, the  button gives the user the following options:

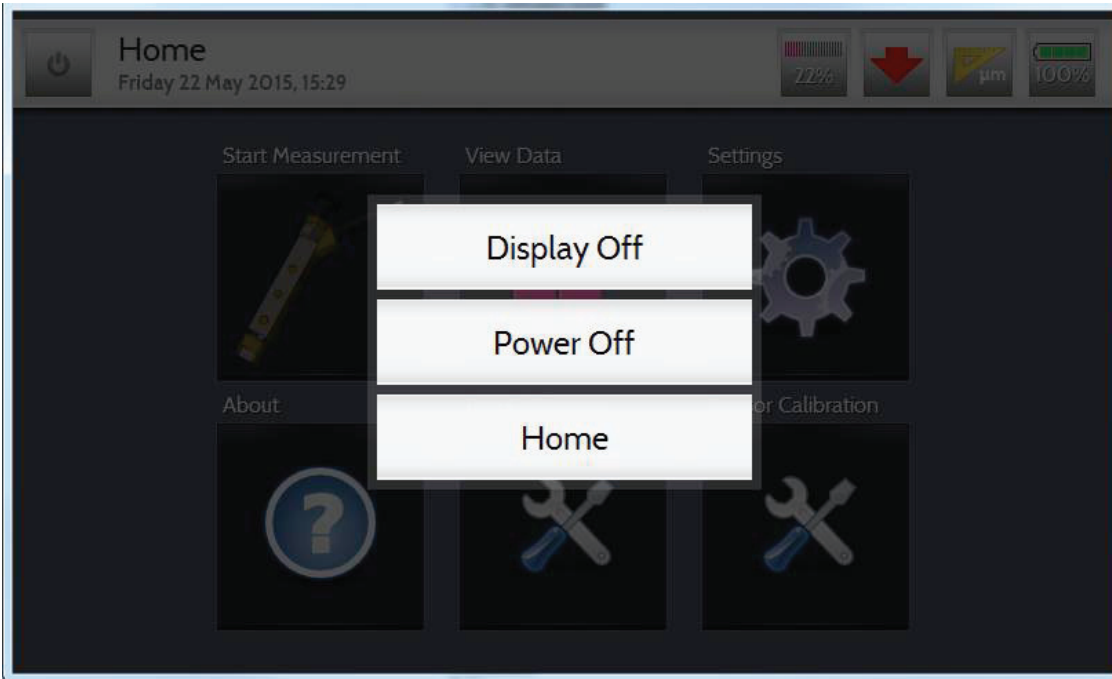

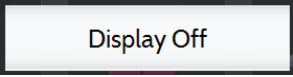
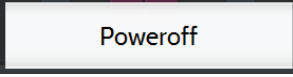
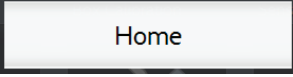
	Turns the screen off
	Turns the unit off
	Returns to home screen

After pressing the “Display Off” button the screen will go blank/turn off; when the screen is then pressed again the following is shown:



Pressing the screen again takes you back to the Home screen

The Power Off button shows the following screen:

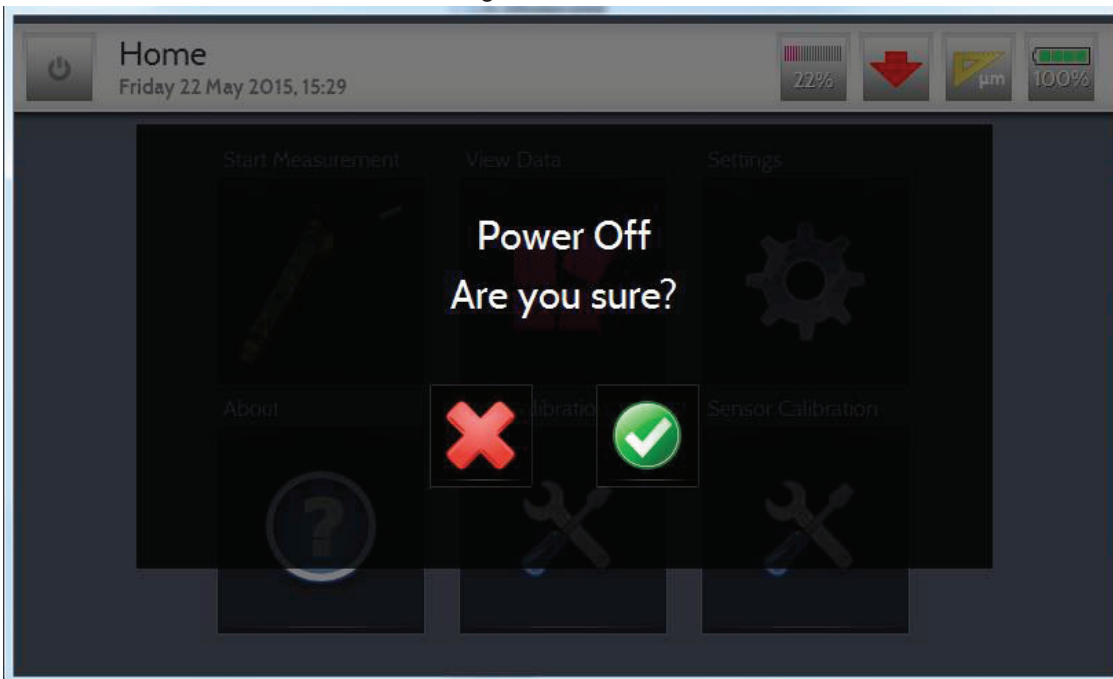

Return to home screen without turning off



Turns unit off

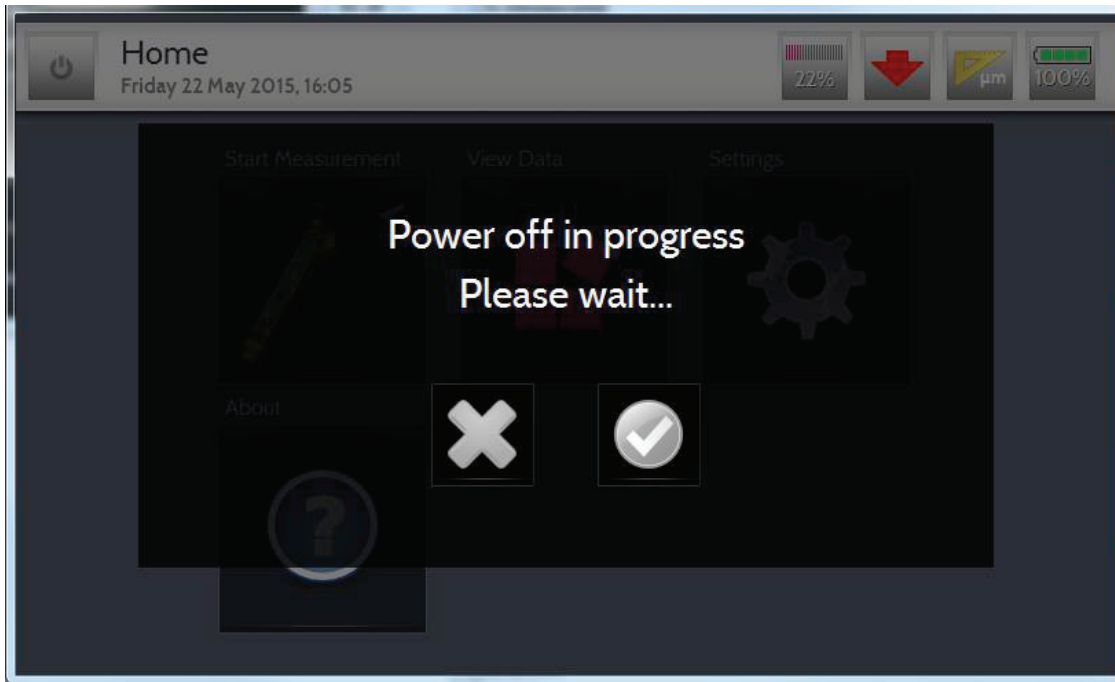

PC ANALYSIS SOFTWARE

DASPro14

To open the DASPro14 software double-click the link as shown below:



GENERAL

- The DASPro14 can be run on a PC or Laptop running Windows® XP or higher.
- Multiple Measuring Boxes can be managed by a single PC or Laptop.
- Only one Measuring Box can be connected to the PC or Laptop at the same time. There will be no support for handling multiple Measuring Boxes simultaneously.
- No licence is needed to run the DASPro14 software.
- Capability to import measuring files from the old PC profiler software
- Prepare a measurement on PC
- Download it to the measuring box

USER INTERFACE

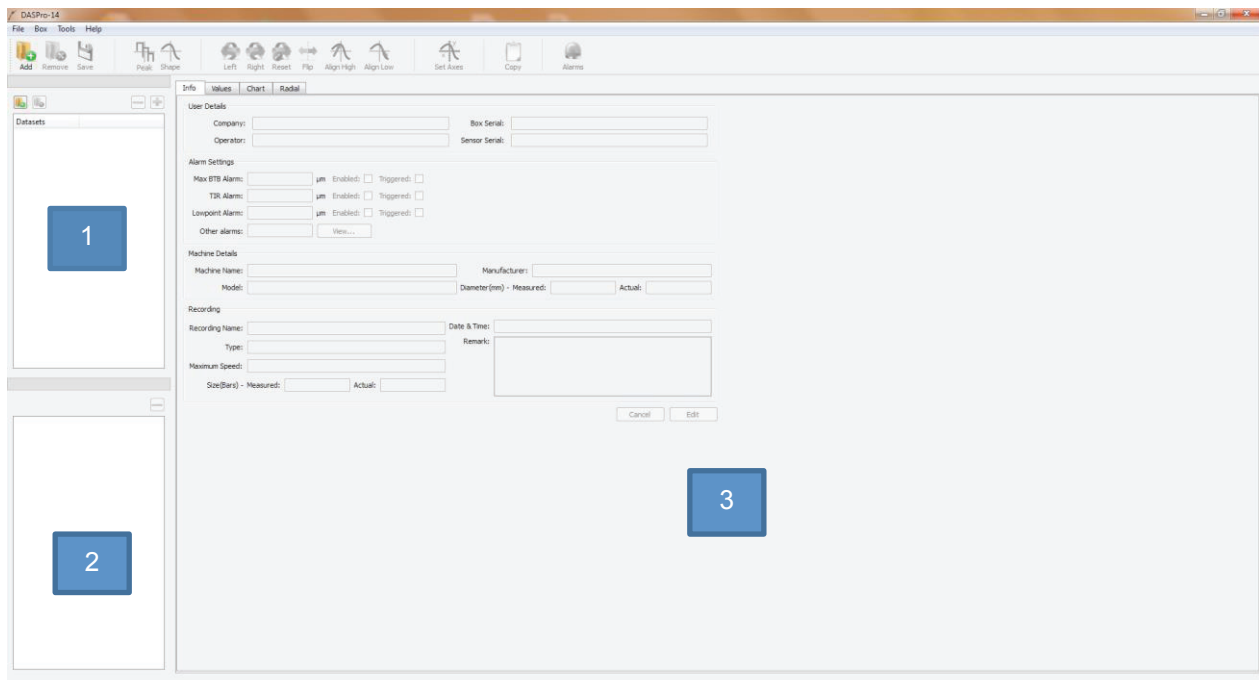

The main window contains the following areas:

- (1) Selected Downloaded datasets
- (2) Recordings list: Selected recordings from the downloaded datasets.
- (3) View area: this area will be used to plot the recordings, show values, etc. and has multiple tabs:

- Tab bar:

1. Info: The info tab shows information about the loaded measurement and allows the user to make changes:

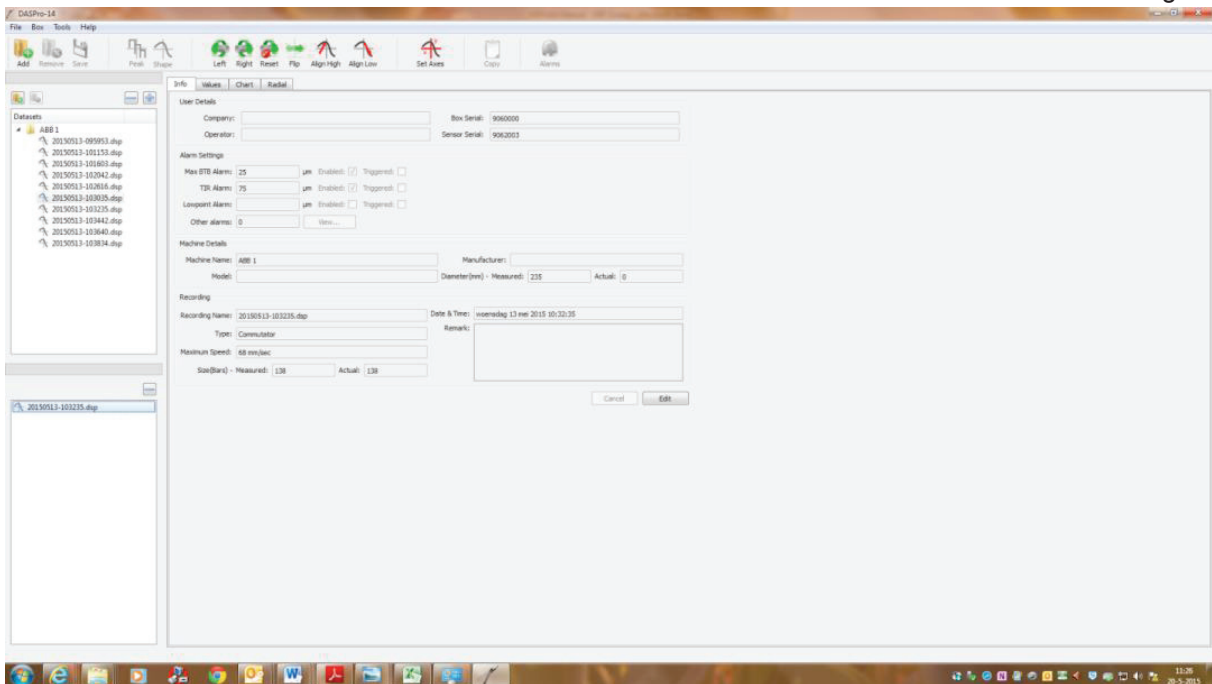

- a) User details (eg. Company, Operator, etc)
- b) Alarm Settings: BTB, TIR, etc.
- c) Recording details (eg. Name, type, size, etc.)

2. Values: This tab will show a table containing the measured values in numeric form. The values can be modified by the user.

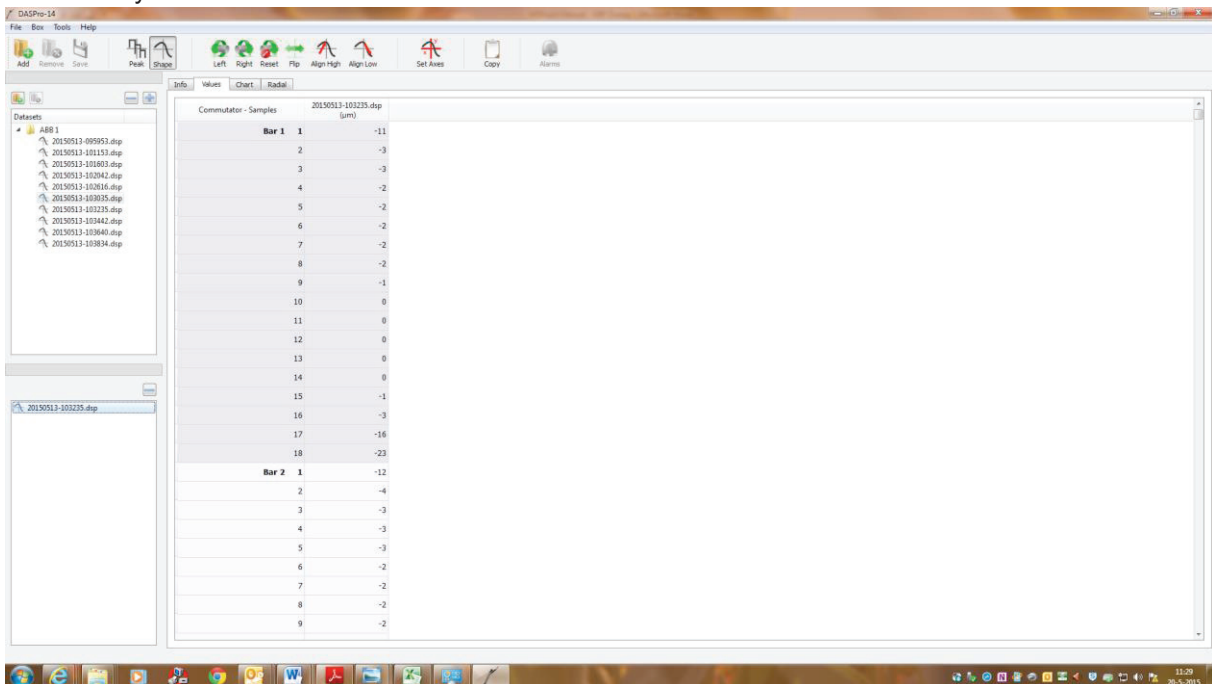

- a) Ability to copy values to clipboard for pasting in another application (for example, Microsoft. Excel)

3. Chart: The chart tab will show a linear plot of the selected recording(s). Available functions are:

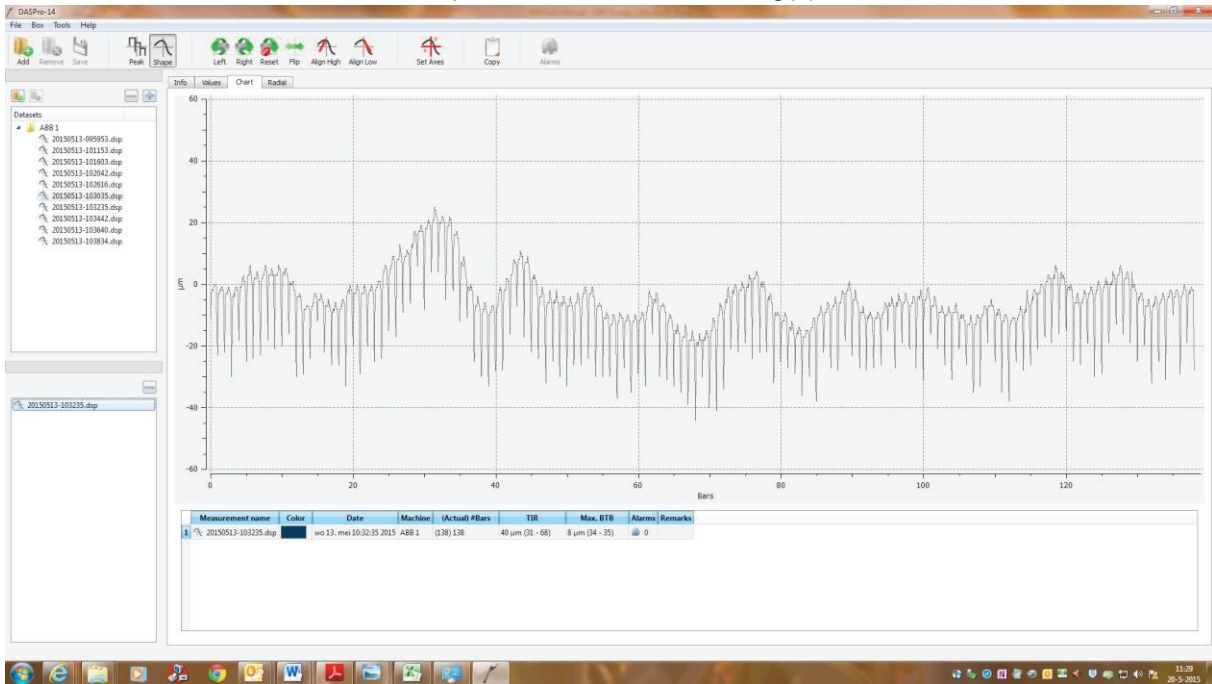

- Pan & zoom
- Rotate, flip & align plot
- Adjust axis scale & colours
- Show/hide horizontal and/or vertical gridlines
- Copy (copy chart plot + legend as a picture on the clipboard)
- Print (chart plot + headers)

4. Radial: The radial plot will show a radial plot of the selected recording(s). Available functions are:

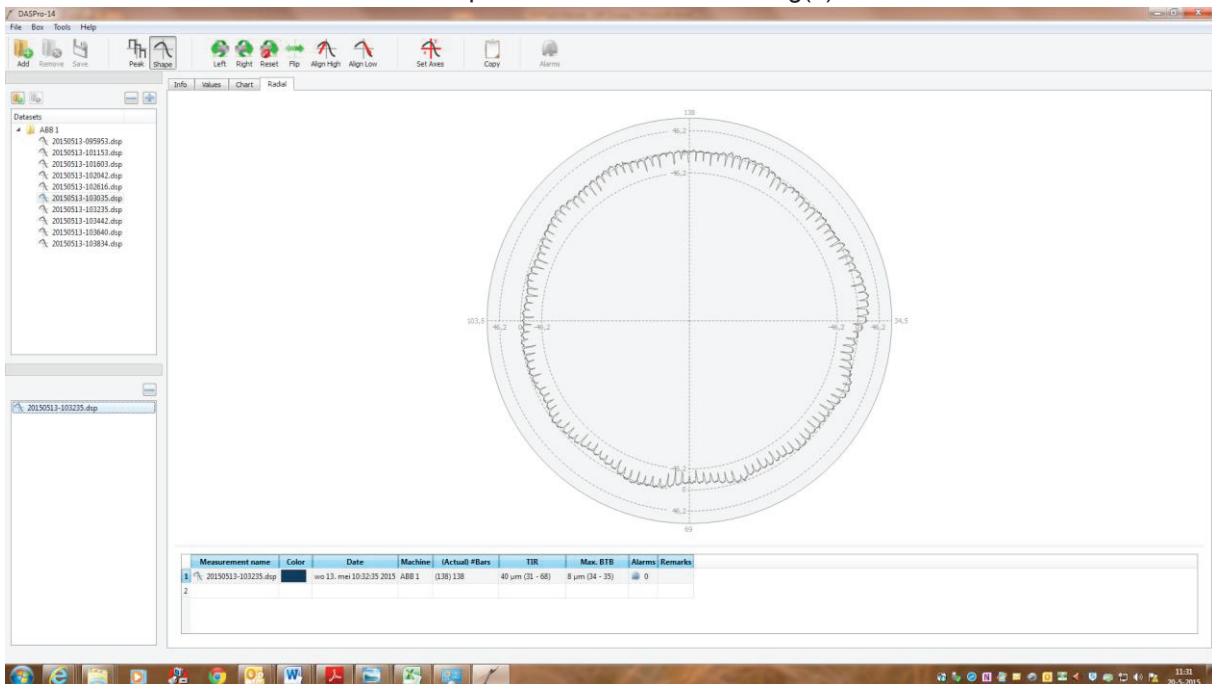

- Pan & zoom

- b) Rotate, flip & align plot
- c) Adjust axes scale & colours
- d) Show/hide middle circle, limit circles and/or central gridlines
- e) Copy radial plot + legend as a picture on the clipboard
- f) Print (radial plot + headers)

- Menu bar
 1. File: file related functions like: open, save, close, etc.
 2. Box
 3. Tools
 4. Help
- Button bar: The button bar will show the most commonly used functions as buttons. Depending on the selected tab, other buttons will be available.
- Status bar: shows status information and is used for showing status information, for example:
 1. Detected Measuring Box
 2. PC/Measuring Box software update available (future option)

USING DASPRO14 FOR THE FIRST TIME

On first use the import folder in which the datasets will be downloaded to needs to be set; the following screen will be displayed: (Note that this can be changed at any time by selecting “Tools>Settings”

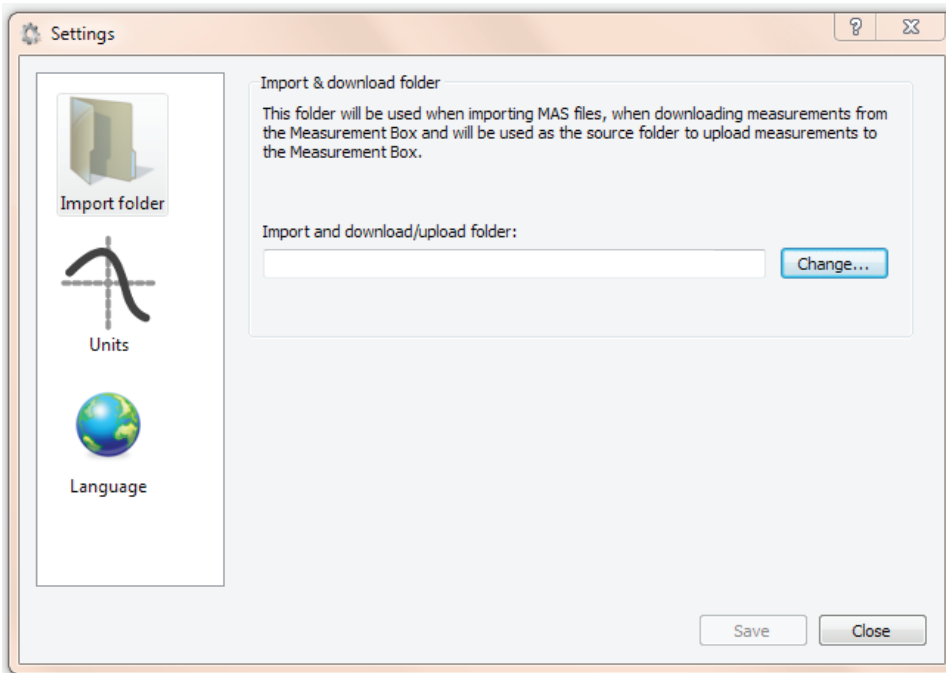

The units and language can also be set in this screen

USING DASPRO14

Adding Datasets

There are 2 ways in which recordings can be added to the import folder:

- As in normal file handling and dragging and dropping the associated files directly from the MPro14 unit

- By selecting “Download from Measurement Box” and following the on-screen instructions

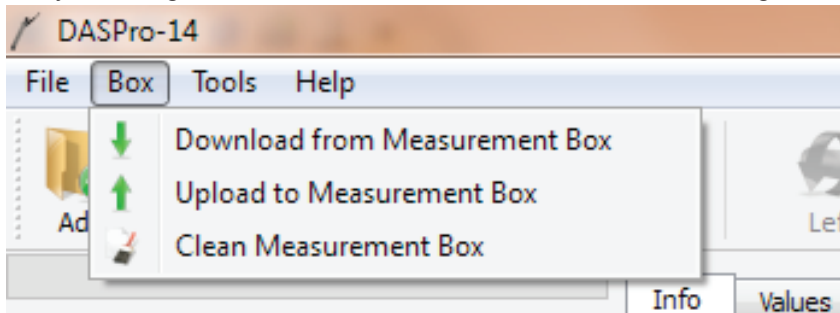

Once there are datasets on the PC, they can be added by pressing the  button; the dataset will then be displayed in the dedicated area. Clicking on the dataset displays the individual recordings:

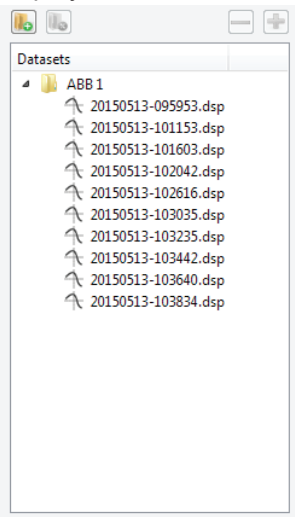

Double-clicking on the individual recording will add it to the recordings list where it can be viewed in detail by selecting one of the 4 different tabs

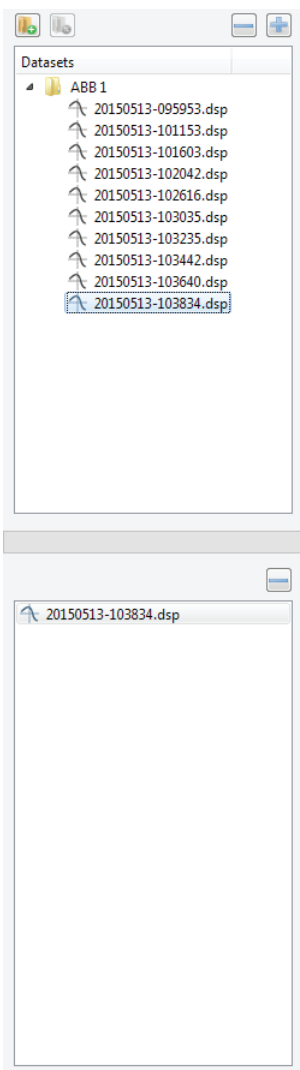

Printing

To print a report on the data, click File>Print Report and select what needs to be printed from the available options and follow on-screen instructions

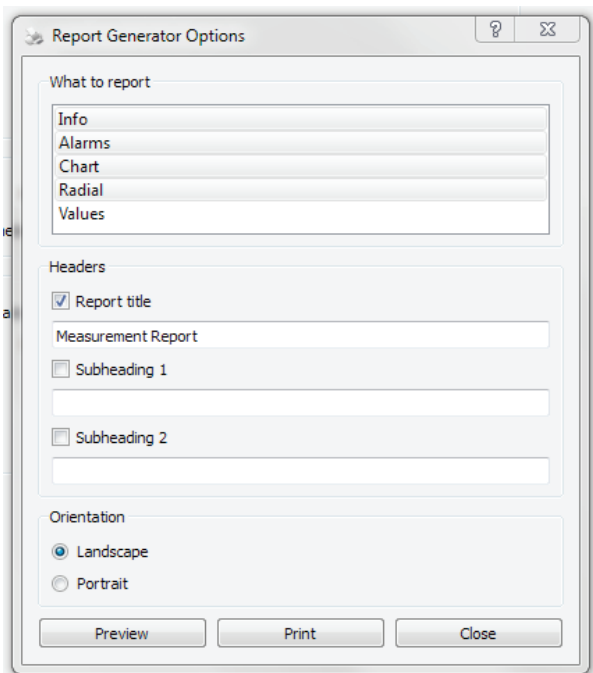

Reading and Comparing Values

- When a chart is displayed it is possible to follow the profile and obtain specific information along the length of the profile; this can be done by placing the cross-hair at the required point and clicking the left mouse button. Once this is done a horizontal and vertical line will appear, and the values indicated by the cross-hair are displayed in the top right-hand corner of the chart
- Note that the cross-hair can be moved by pressing the left and right arrows on the keyboard

Adjusting Profiles

There are 6 different buttons available to allow the user to adjust the way in which the profiles are displayed and mean that profiles that were taken on the same machines, but from different starting positions, can be aligned.



Left

Move the profile left by one bar/segment



Right

Move the profile right by one bar/segment



Reset

Return the profile to its original position



Flip

Mirroring the profile



Align High

When there are 2 or more profiles this aligns the profile to the highest bar/segment



Align Low

When there are 2 or more profiles this aligns the profile to the lowest bar/segment

Zooming behaviour

- Zooming is only possible in the Chart and Radial tabs. To zoom in on any part of a chart:
 1. Left-click a place on the left side of the chart section you wish to zoom.
 2. Hold down the mouse button while you drag a rectangle across and down to the right.
 3. Release the mouse button to perform the zoom. To zoom in horizontally:
 4. Proceed as above, but only move the mouse directly left or right to select the area to be enlarged. Two vertical lines will be displayed across the chart to indicate the selection.
- To zoom in vertically:
 1. Proceed as above, but only move the mouse directly up or down to select the area to be enlarged. Two horizontal lines will be displayed across the chart to indicate the selection.
- To zoom out from any view:
 1. Left-click any place in the chart and drag a rectangle across and up to the left to display a rectangle with a cross in it. When you release the mouse button the chart will return to its original size and location.

Alarms

The PC-Software can check the commutator and slip ring recordings for the following alarm conditions. If the

button is in colour  Alarms then it will indicate that an alarm has been triggered on the selected profile, if black

and white  Alarms then no alarms are triggered:

- TIR - Total Indicated Runout
 - The difference between the highest and lowest points on the profile.
- MBTB - Maximum Bar-to-bar
 - The difference in height between adjacent commutator bars.
- MSTS - Maximum Segment to segment
 - The difference in height between adjacent slip ring segments.
- High Mica
 - Lists any Mica insulation (between commutator bars) which are not recessed below the bar surface.

Downloading .Mas files

It is possible to download profiles taken on the previous version of the profiler that Morgan used to offer; this can be done by selecting “File>Importing MAS File...” and following the on-screen instructions.

APPENDIX A: SPECIFICATIONS

These specifications may be changed in future versions:

Specifications	MSPro I4™ Surface Profiler	Remarks	Specifications	MSPro I4™ Surface Profiler	Remarks
Range	± 1000 µm (± 40 mil)	Imperial/Metric is user-selectable	Communications	USB 2.0	
Resolution	1 µm (0.04 mil)		Battery Type	Li-Ion	
Accuracy			Voltage	3.7V nominal	
TIR	± 2% ± 4 µm (0.16 mil)		Capacity	7800 mAh nominal	
Diameter	± 0.5% for all collectors	with diameter ≥ 200mm/7.9"	Operating Time	6 hours nominal	
Sampling Interval	Maximum recording speed 100mms-1 (4 ins-1)	Ensures consistent results	Charger & Conditioner	Charge over USB	All charging equipment included
Memory Data Storage	Up to 250 named Data Sets	Depends on size of collectors	Charge rate	1.5A (via USB mains charger) 0.5A (via PC charger)	
Capacity	32MB		Mechanical Size	247mm(W)x154mm(L) x75mm(H) (9.7"(W)x6.1"(L)x3.0"(H))	
Display Type	LCD with graphic capabilities		Weight-Base Unit	1 kg (2.2lb)	
Resolution	800 x 480 pixels		Complete kit	4kg (8.8lb)	
Viewing Area	150mm x 85mm (6.0"x3.4")		Environmental Temperature	0°C – 50°C (32°F – 122°F)	
Backlight	LED		Humidity	70% RH: 0°C – 50°C (32°F – 122°F) 80% RH: 0°C – 30°C (32°F – 86°F)	
Sensor Connection	Custom 8 pin round plug		Non-condensing	95% RH: -10°C – 60°C (14°F – 140°F)	
			EMC	EN61000-3-2:2006/A2:2009 EN61000-6-2:2005	Radiated and conducted emissions RF field, ESD and fast transient immunity



APPENDIX B: WARRANTY & REPAIRS

Warranty

The warranty covers construction and material faults of the MSPro14 equipment and the warranty period is valid for 1 year after invoicing.

Damage due to incorrect or inexpert handling is excluded from the warranty. Do not open the housing of the MSPro14 unit yourself as this will invalidate the warranty.

Repairs & Calibration

Repairs can and will be done by (or under the authority of) the developer/manufacturer; **this can also be done elsewhere but this is at the Users own risk.**

In the unlikely event that repairs are necessary please contact your local Morgan sales office. They can inform you on how to proceed. You can contact them as well if you want to have your MSPro14 calibrated.

MORGAN ADVANCED MATERIALS

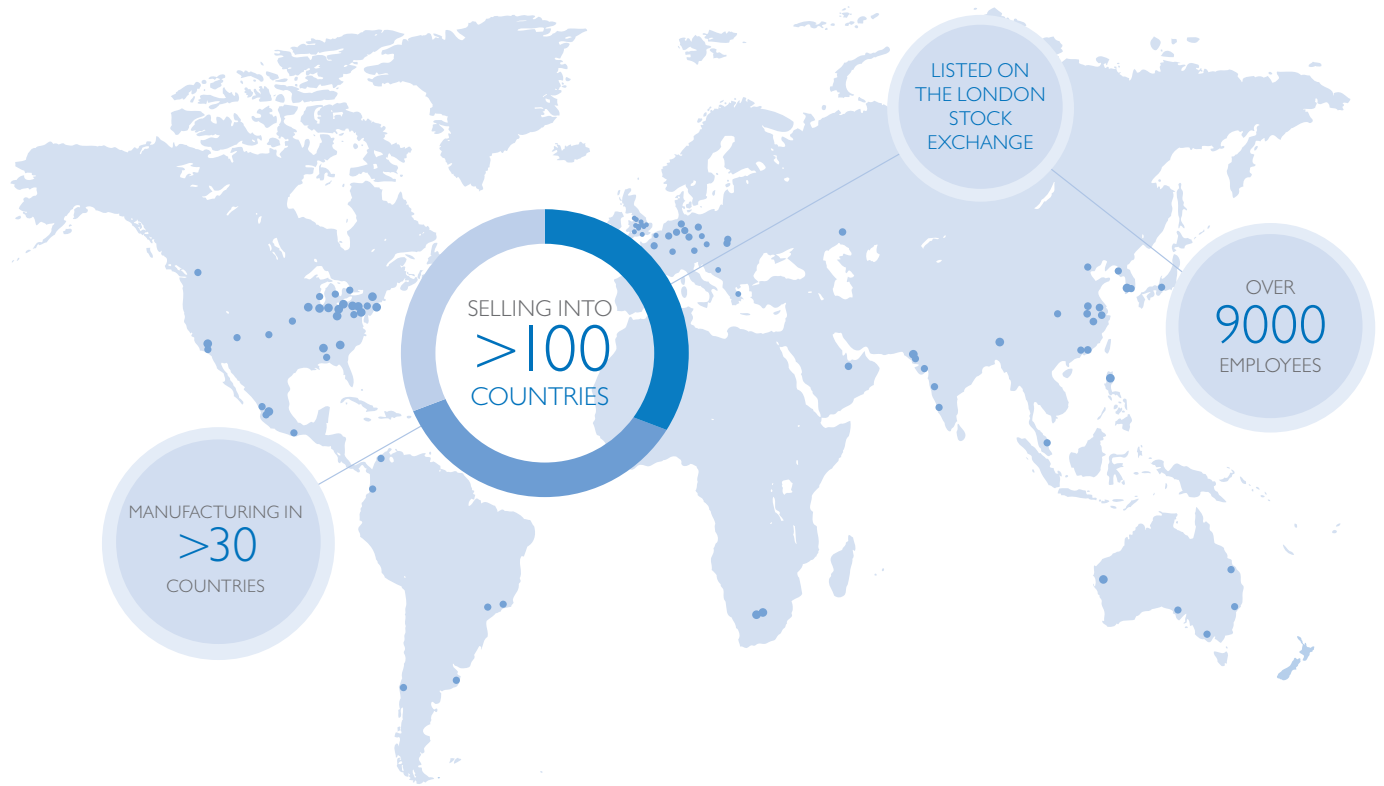

For all enquiries, please contact our specialist sales and manufacturing sites:

The Netherlands

Morgan Advanced Materials
Oude Veiling 3
1689 AA Zwaag
The Netherlands

T +31 229255555
F +31 229255541
salesNL@morganplc.com

China

Morgan Advanced Materials
4250 Longwu Rd.
Shanghai 200241
China

T +86 (21) 64342745
F +86 (21) 64342850
chinasales@morganplc.com

USA

Morgan Advanced Materials
251 Forrester Drive
Greenville, SC 29607
USA

T +1-864-458-7777
F +1-864-281-0180
nasales@morganplc.com

Asia

Morgan Advanced Materials
21 Amour Street, Revesby
NSW, 2212
Australia

T +61 2 9772 5600
F +61 9774 5677
morgan.australia@morganplc.com



Visit our website
www.morganadvancedmaterials.com



Follow us on
twitter.com/morganadvanced



Follow us on
facebook.com/MorganAdvancedMaterials



Follow us on
linkedin.com/company/morgan-advanced-materials

Morgan Advanced Materials plc
Quadrant, 55-57 High Street,
Windsor, Berkshire, SL4 1LP United Kingdom

www.morganadvancedmaterials.com